



Greening the Grid

Utility-Scale Battery Storage: When, Where, Why and How Much?

Paul Denholm | Principle Energy Analyst, National Renewable Energy Laboratory | February 27, 2019



Overview

In power systems with increasing levels of variable RE...

- **What type** of battery storage is valuable for the power system?
- **What type** of storage will be valuable *in a high RE system*?
- Is battery storage needed to integrate renewable energy? **(Why?)**
- **How much** storage is appropriate?
- **Where** should battery storage be located?
- **When** does battery storage become cost-effective?

Answers to these questions are complex and system-specific. Some trends are emerging...

Key Takeaways

- In most power systems, storage isn't yet needed to integrate larger amounts of variable RE.
 - “Stand-alone” RE integration applications are typically not cost effective...yet
- Storage applications need to consider duration, location, and ability to combine and monetize multiple services
- Storage is increasingly cost competitive for short-duration ancillary services, and long duration applications that combine some elements of capacity, energy and transmission services
- As RE penetration increases, this increases the value of storage, and storage becomes an increasingly valuable tool for RE integration
 - There are important potential tradeoffs when considering co-location of storage with RE or siting storage closer to load

Key concepts and definitions

Why all the hype, and why now?

Lithium-ion battery price survey, 2010-16 (\$/kWh)

Source: Bloomberg New Energy Finance, *Lithium-ion Battery Costs and Market* (July 2017)

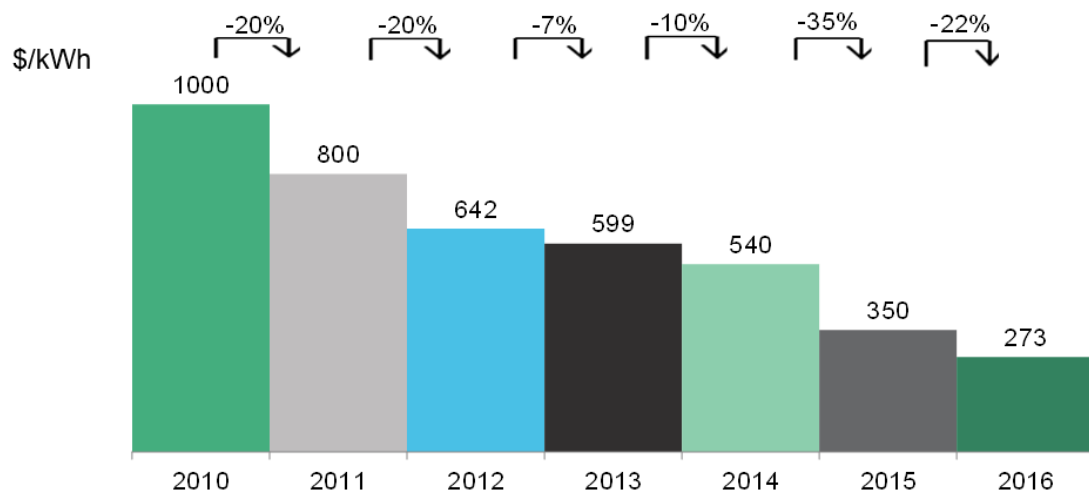

73% cost reduction since 2010 due to technology improvements, economies of scale, manufacturing competition

Global Cumulative Storage Deployments, 2016-2030 (GWh)

Source: Bloomberg New Energy Finance (November 2017)

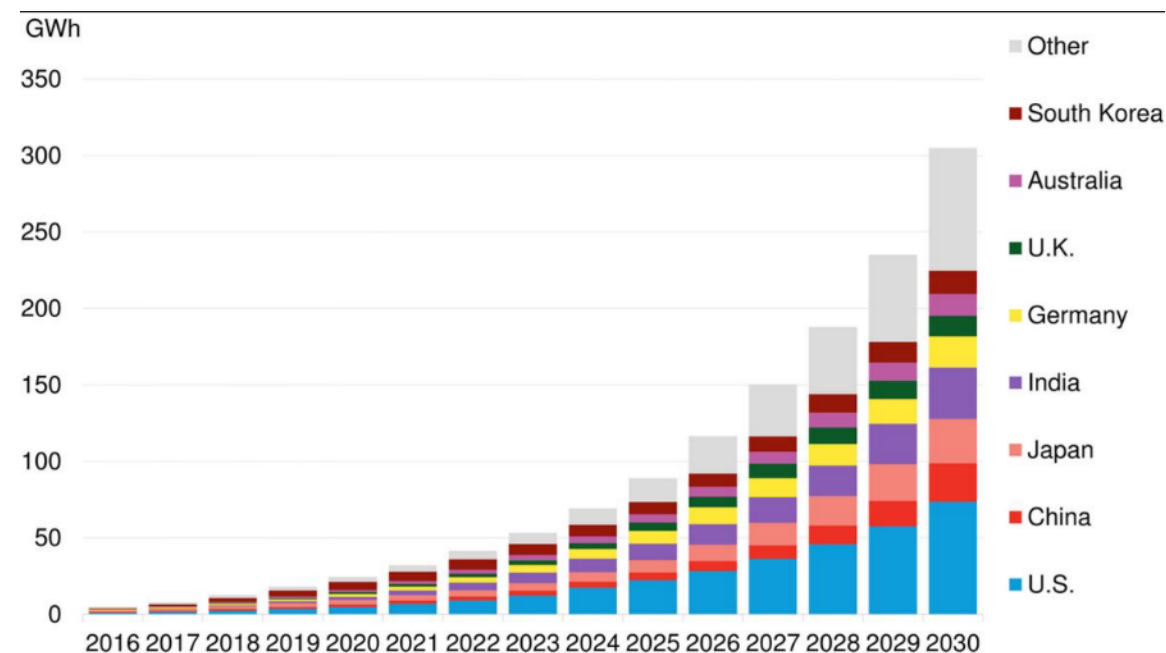

Similar trajectory to PV deployment in early 2000s

What type of battery storage is valuable for the power system?

What type?

- Applications for energy storage are defined by the following parameters:
 - **Power capacity (kW):** rate of charge or discharge (in kilowatts or megawatts)
 - **Energy capacity (kWh):** amount of stored energy (in kilowatt-hours or megawatt-hours)
 - **Storage duration:** amount of time storage can discharge at its power capacity before depleting its energy capacity

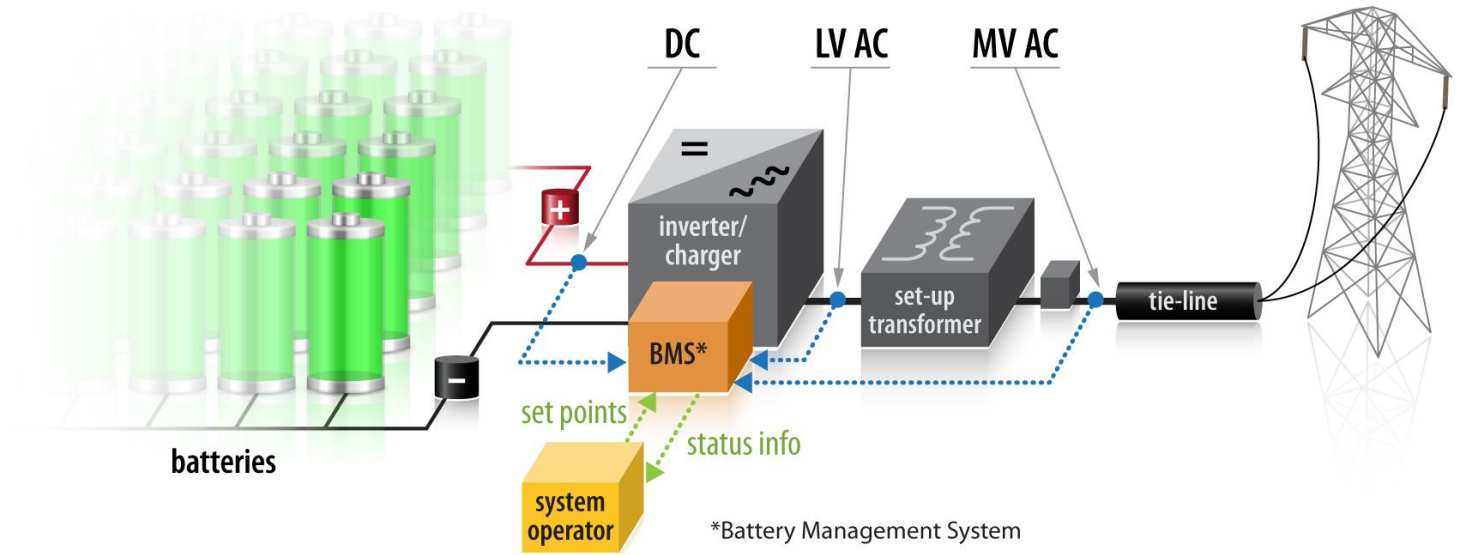

For example, a battery with 1 MW of power capacity and 4 MWh of usable energy capacity will have a storage duration of 4 hours.

Is Battery Storage Needed to Integrate Renewable Energy?

Balancing Supply and Demand – The Importance of System-Wide Net Load

- Net load is energy demand after accounting for solar and wind generation
 - This is the energy demand that must be met by other resources on the power system (e.g., thermal, hydro, storage, energy trade, demand response)
 - Net load (like normal load without RE) is best balanced at the system level

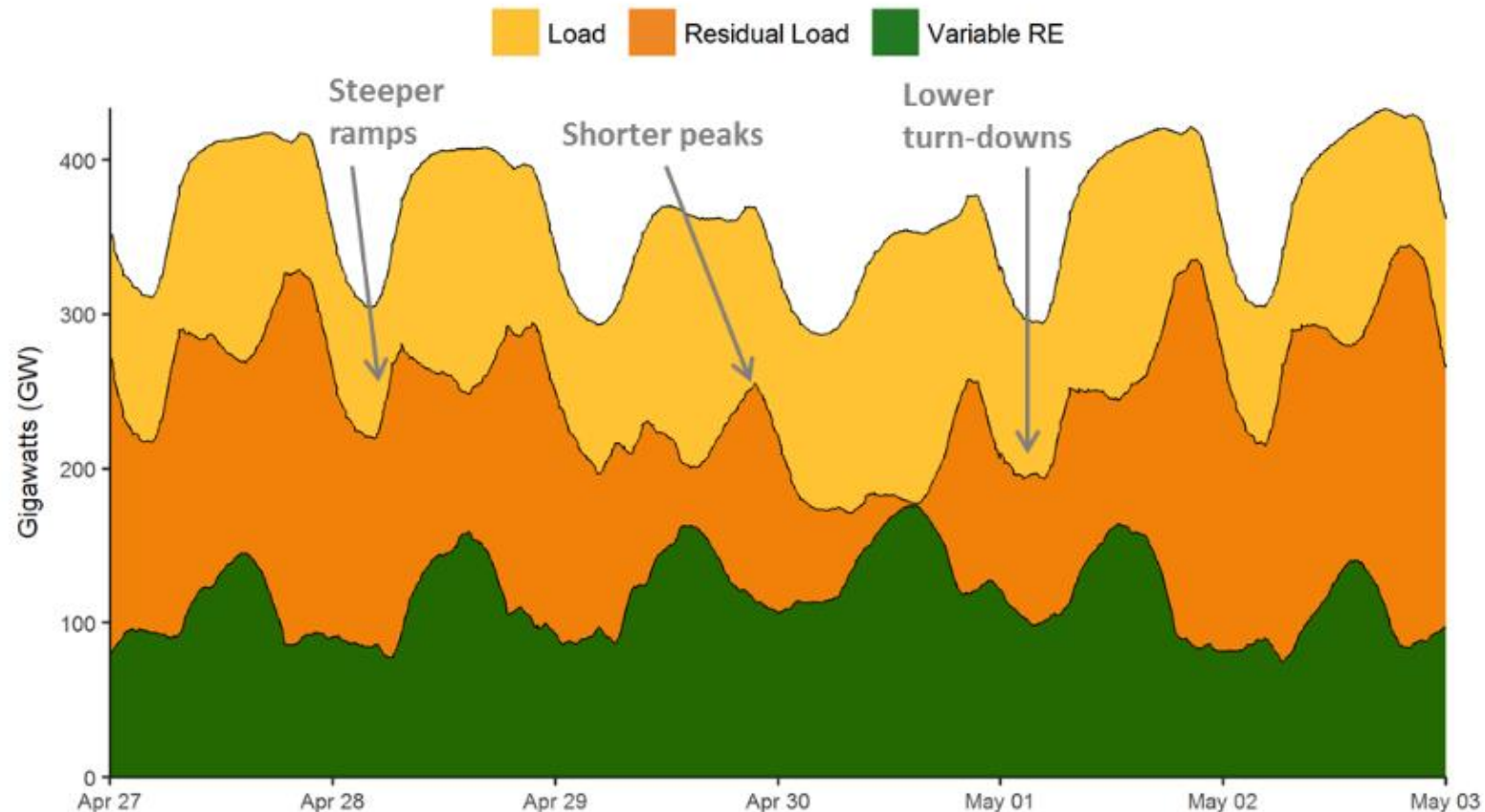
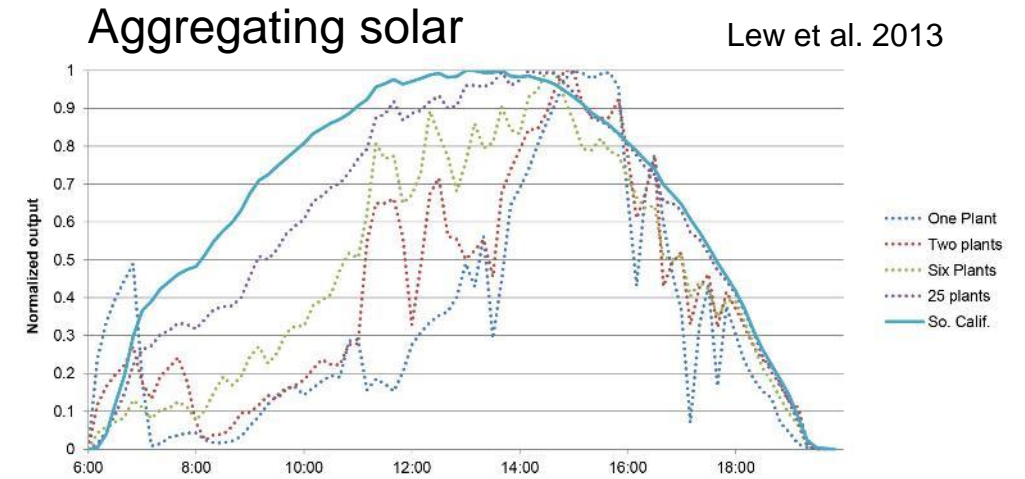

Figure source: NREL
Report No. FS-6A20-
63039

Do Individual Renewable Energy Plants Require “Backup” From Battery Storage?

Why batteries?

- We don't balance or “firm” individual loads
- Why should we balance individual generators?
- The variability and uncertainty of loads and generators are best optimized at a system level
- We of course need to address any additional need for operating reserves, transmission constraints etc.
- Need to consider impacts of spatial diversity and all sources of flexibility for integrating VRE



Balancing individual solar plants could result in simultaneous charging AND discharging

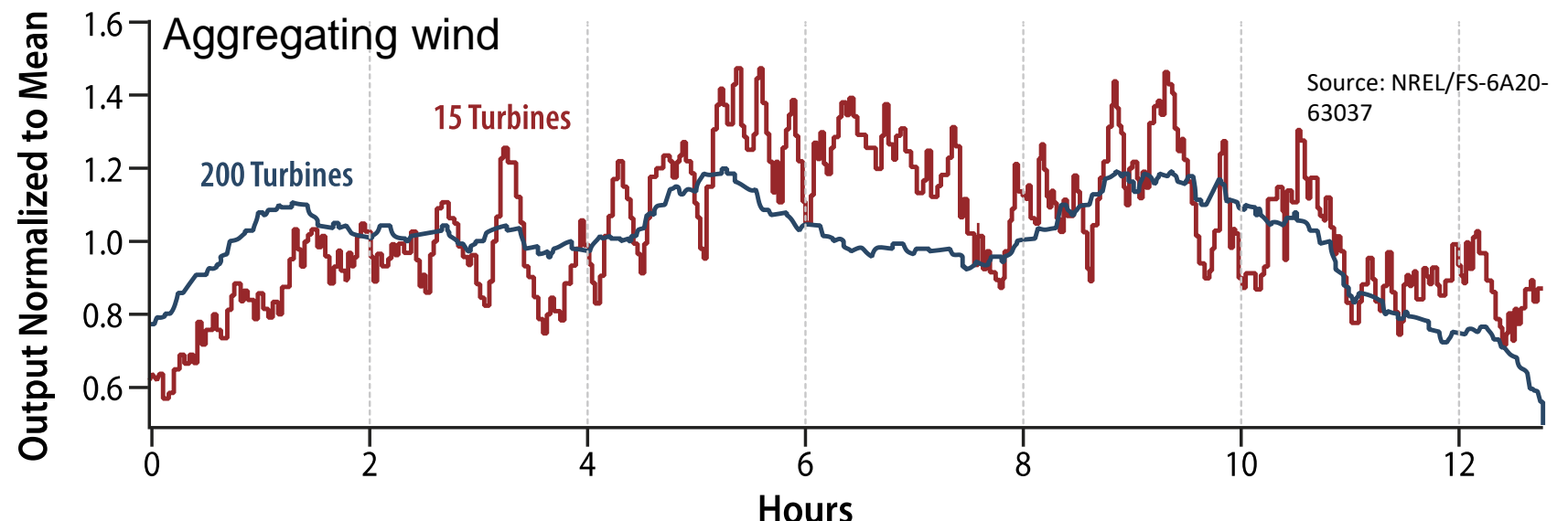

Battery Storage Can be Considered as Part of the Flexibility Supply Curve

When?

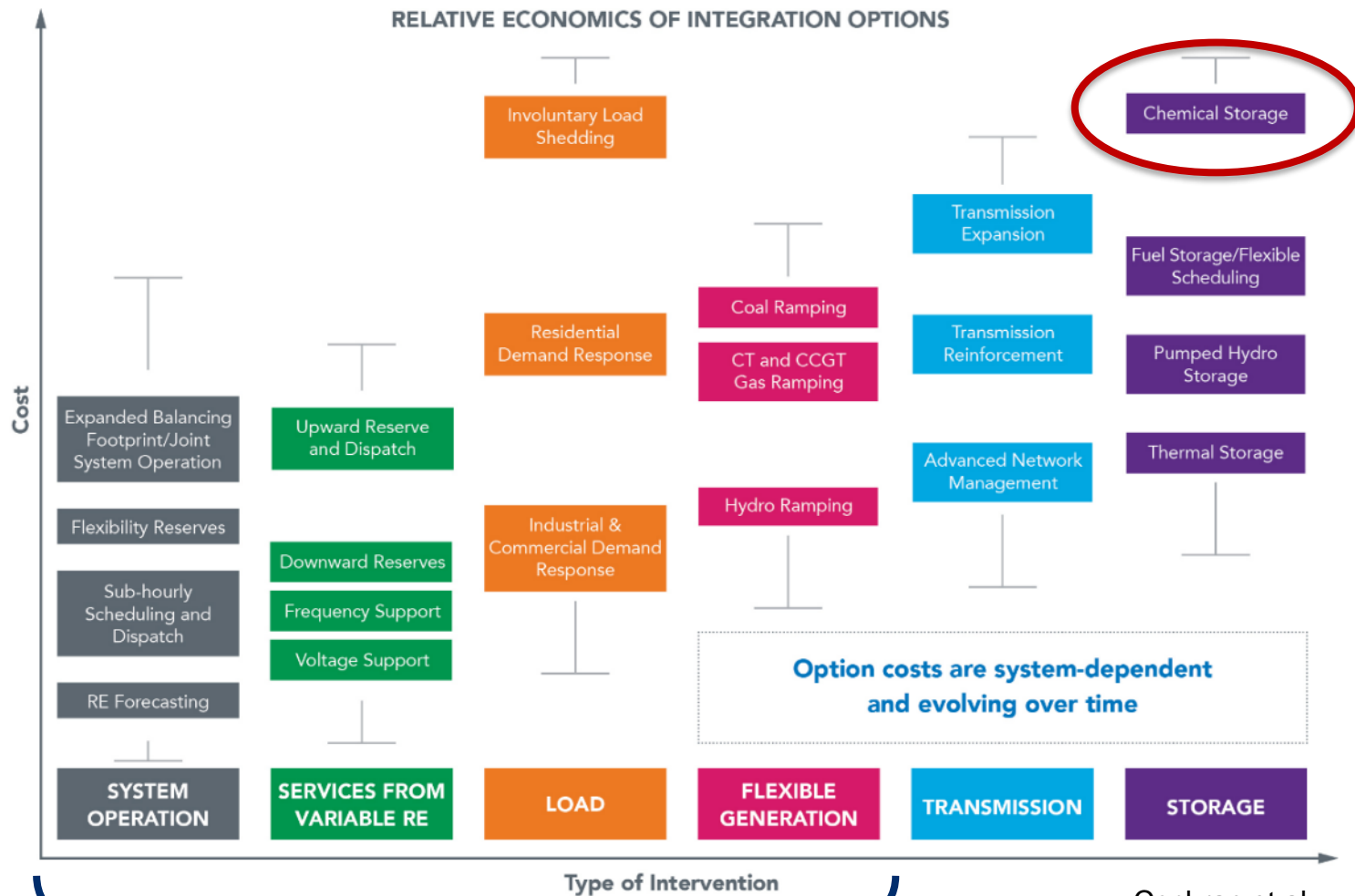

Battery storage has historically been among the most expensive options for the integration of renewable energy (or any grid service)

But that is changing

You probably do this first

Cochran et al. 2015

What type of battery storage is valuable for the power system?

What type of storage will be valuable *in a high RE system?*

What type?

Battery storage applications and potential value streams

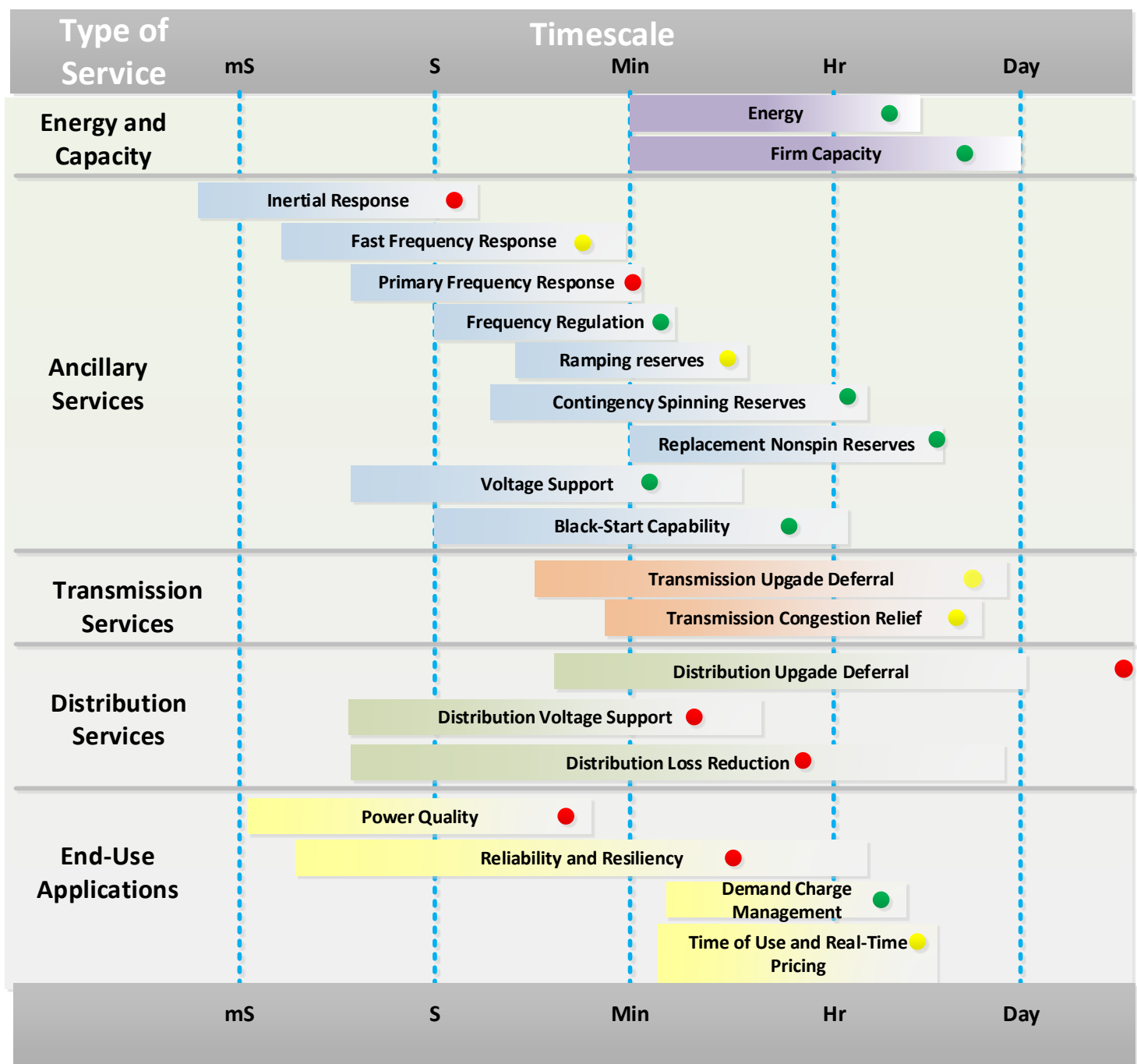

- Services currently valued in some markets
- Proposed or early adoption services
- Currently not valued services

What type?

Battery storage applications and potential value streams

- **Storage can provide a range of grid services at different timescales**
- Value stacking enables storage projects to monetize a range of streams
- Markets and planning need to evolve to enable power system services that storage (and other technologies) can provide
- Renewable integration is largely captured by existing service categories

How quickly initial response is needed

How long response is needed

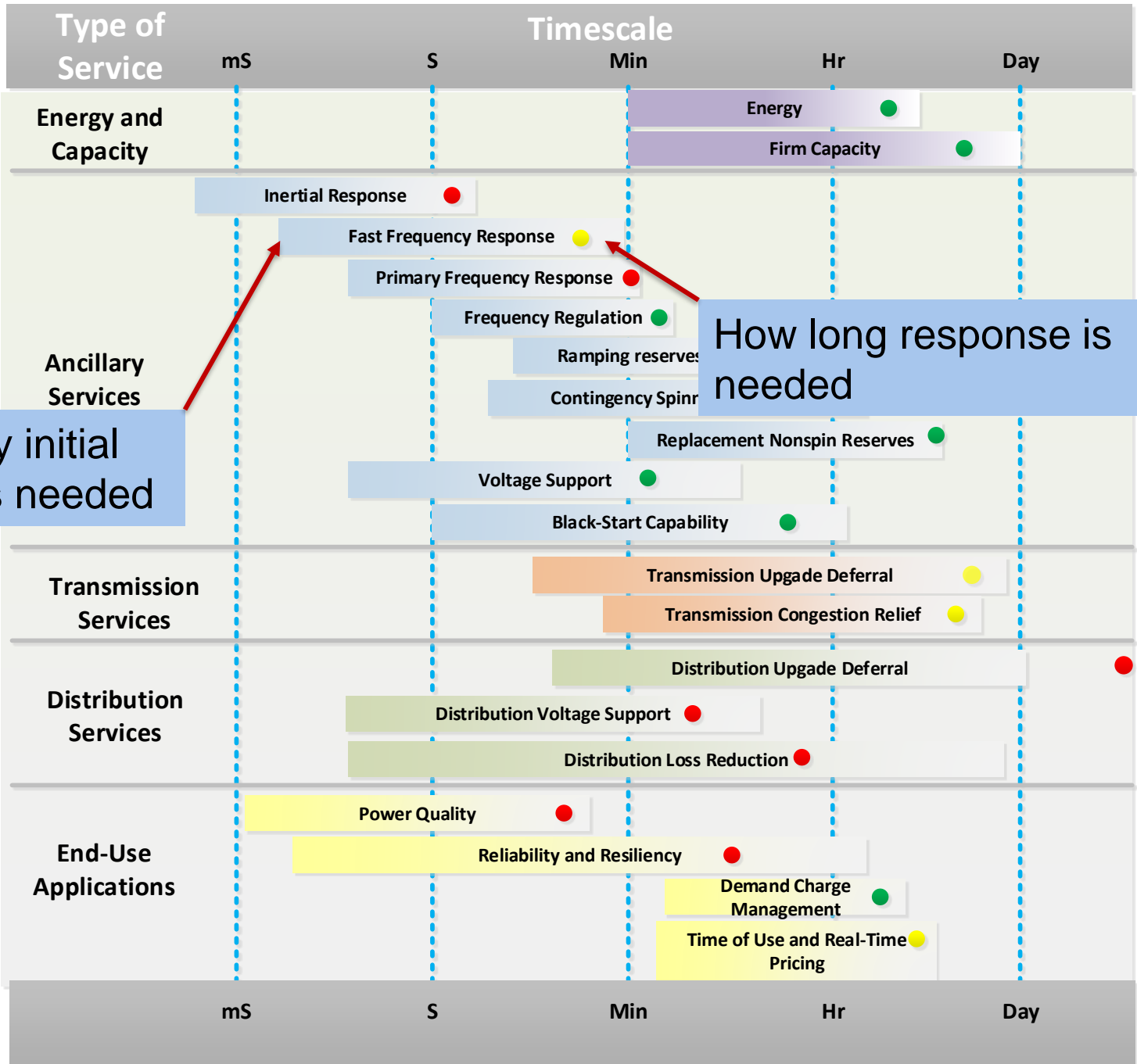

- Services currently valued in some markets (Green dot)
- Proposed or early adoption services (Yellow dot)
- Currently not valued services (Red dot)

What type?

Battery storage applications and potential value streams

- Storage can provide a range of grid services at different timescales
- Value stacking** enables storage projects to monetize a range of value streams
- Markets and planning need to evolve to enable power system services that storage (and other technologies) can provide
- Renewable integration is largely captured by existing service categories

- Services currently valued in some markets
- Proposed or early adoption services
- Currently not valued services

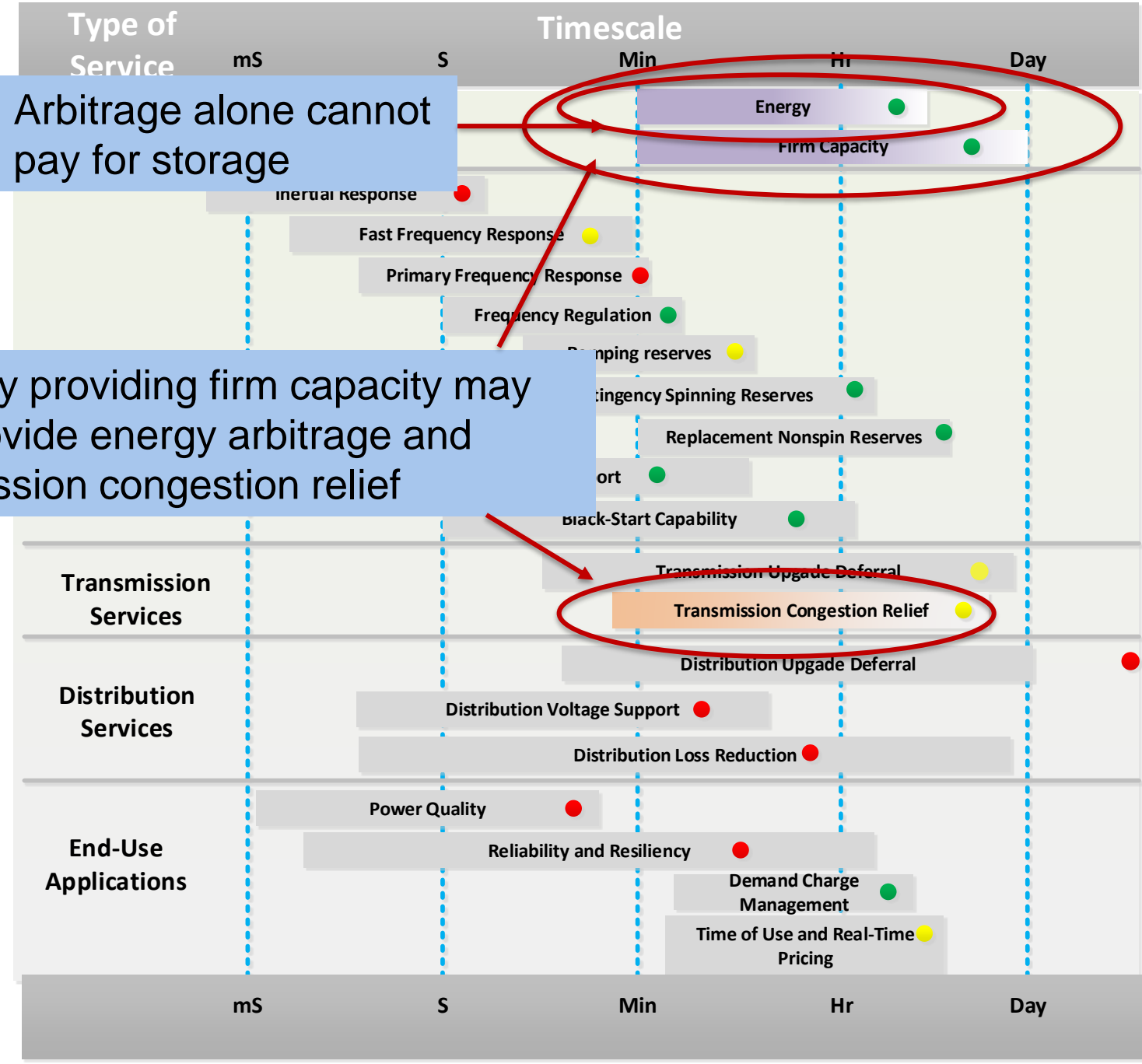

Arbitrage alone cannot pay for storage

A battery providing firm capacity may also provide energy arbitrage and transmission congestion relief

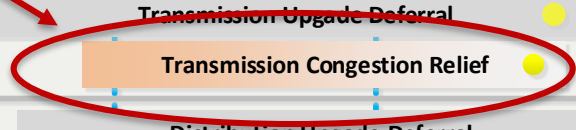
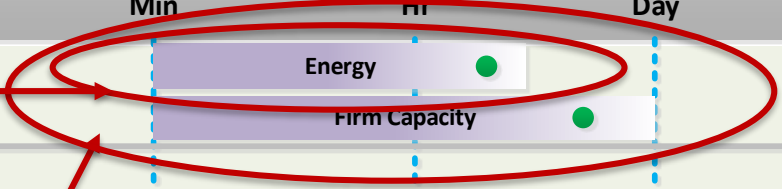

What type?

Battery storage applications and potential value streams

- Storage can provide a range of grid services at different timescales
- Value stacking enables storage projects to monetize a range of value streams
- Markets and planning need to evolve to enable power system services that storage (and other technologies) can provide
- Renewable integration is largely captured by existing service categories

- Services currently valued in some markets
- Proposed or early adoption services
- Currently not valued services

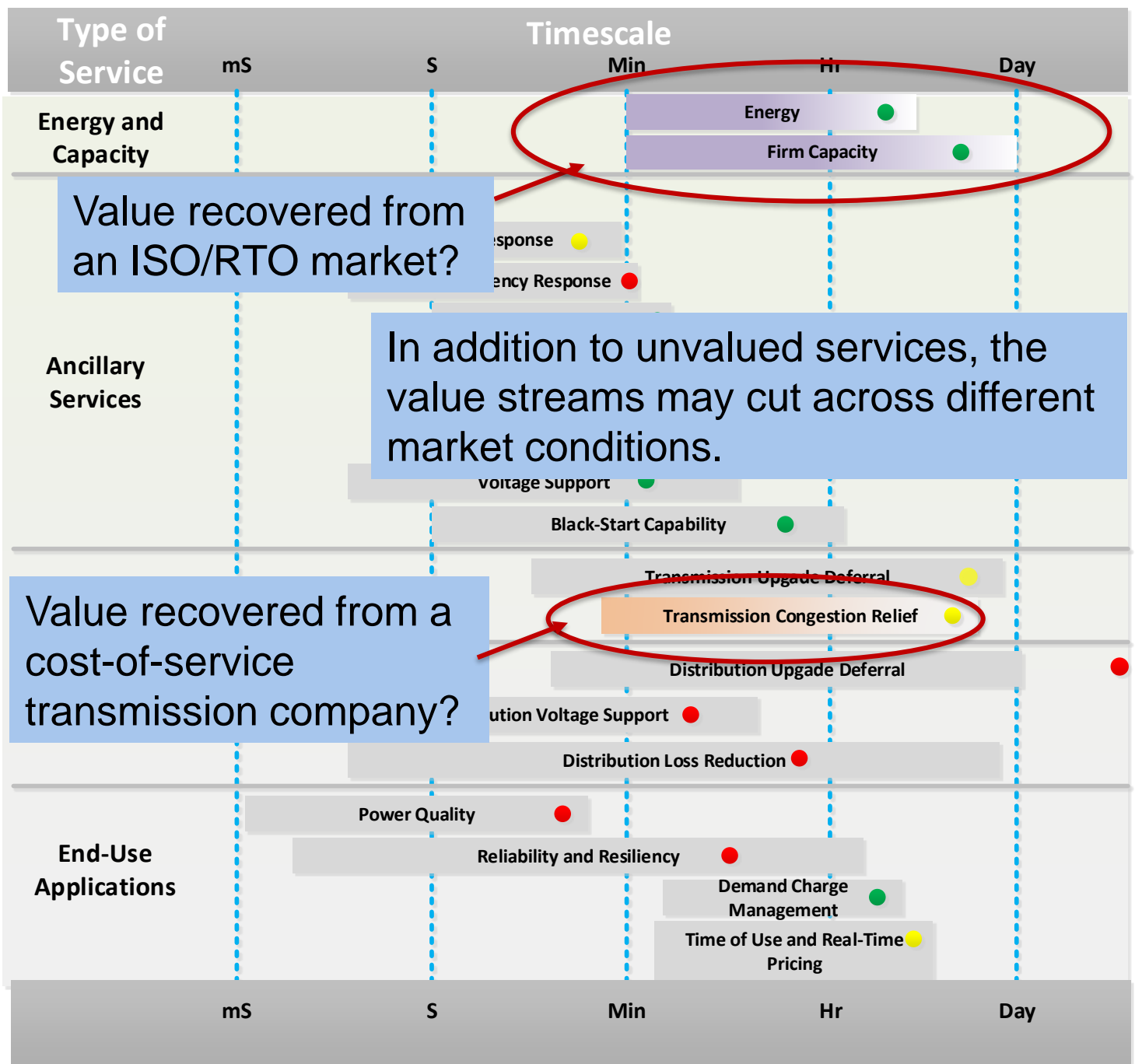

Value recovered from an ISO/RTO market?

In addition to unvalued services, the value streams may cut across different market conditions.

Value recovered from a cost-of-service transmission company?

What type?

Battery storage applications and potential value streams

- Storage can provide a range of grid services at different timescales
- Value stacking enables storage projects to monetize a range of value streams
- Markets and planning need to evolve to enable power system services that storage (and other technologies) can provide
- **Renewable integration is largely captured by existing service categories**

● Services currently valued in some markets
● Proposed or early adoption services
● Currently not valued services

Renewable time-shifting and curtailment mitigation

Renewable "firming"

Renewable ramping

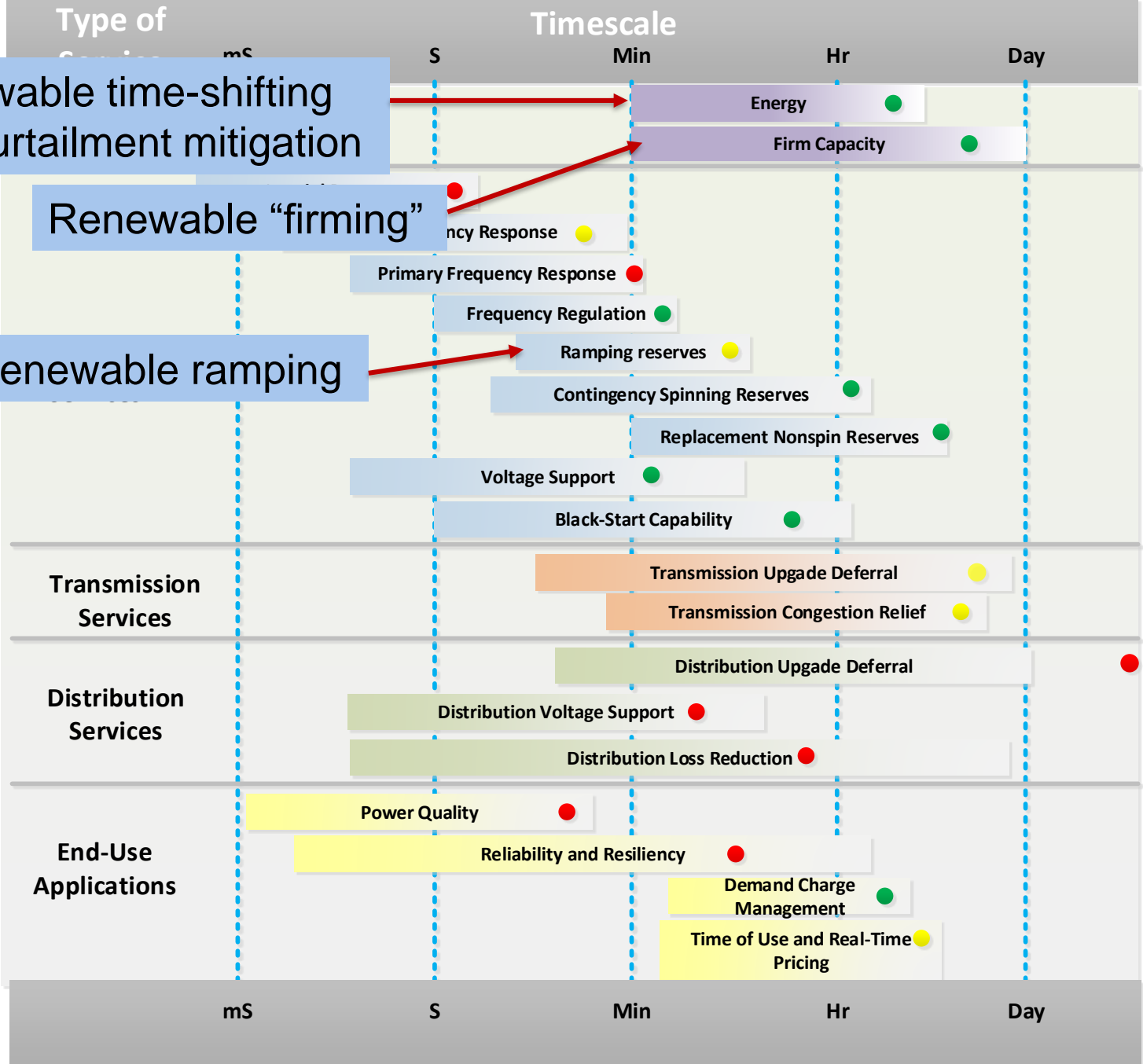

What type?

Battery storage applications and potential value streams

Ongoing competition from various other flexibility resources

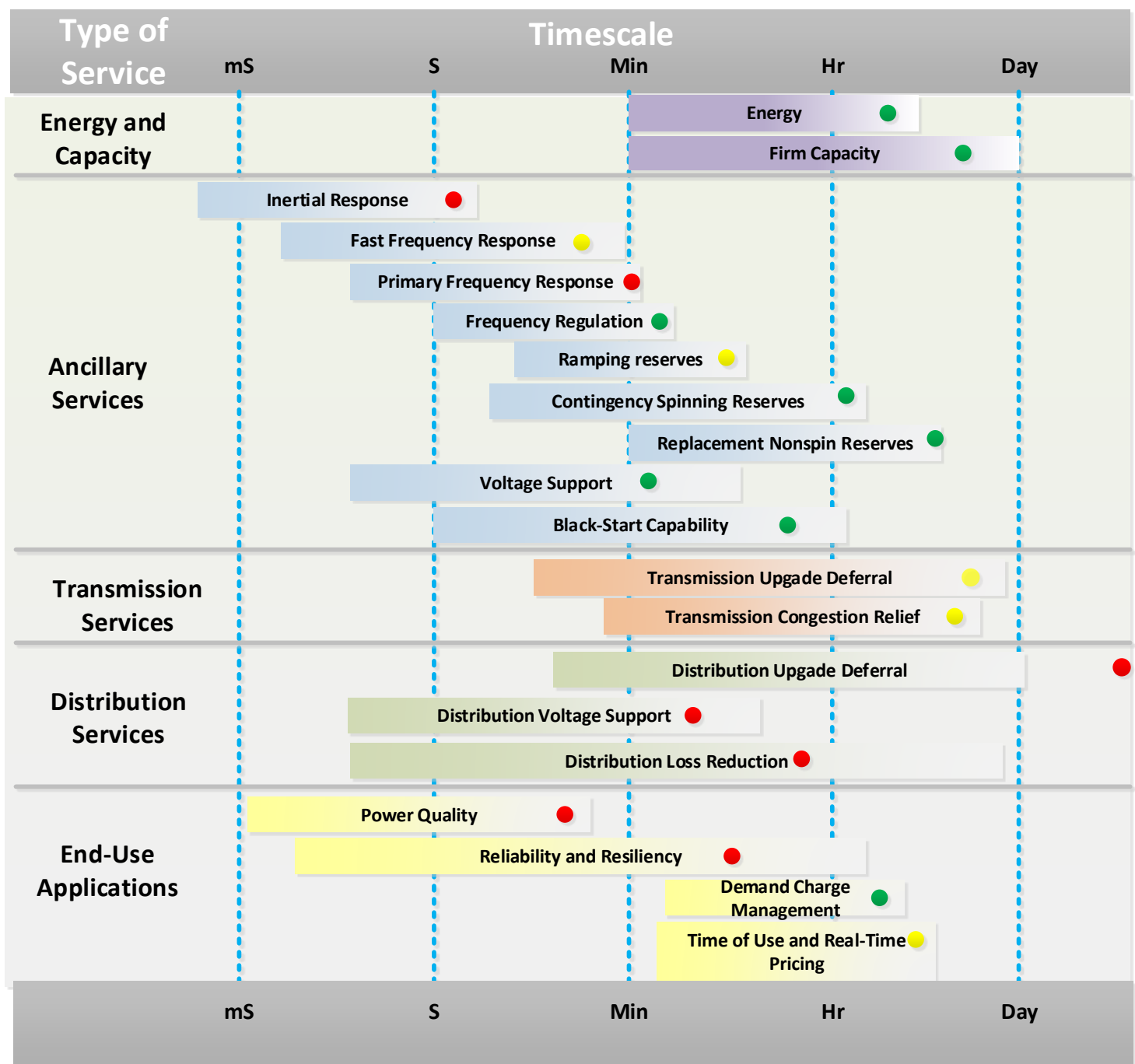
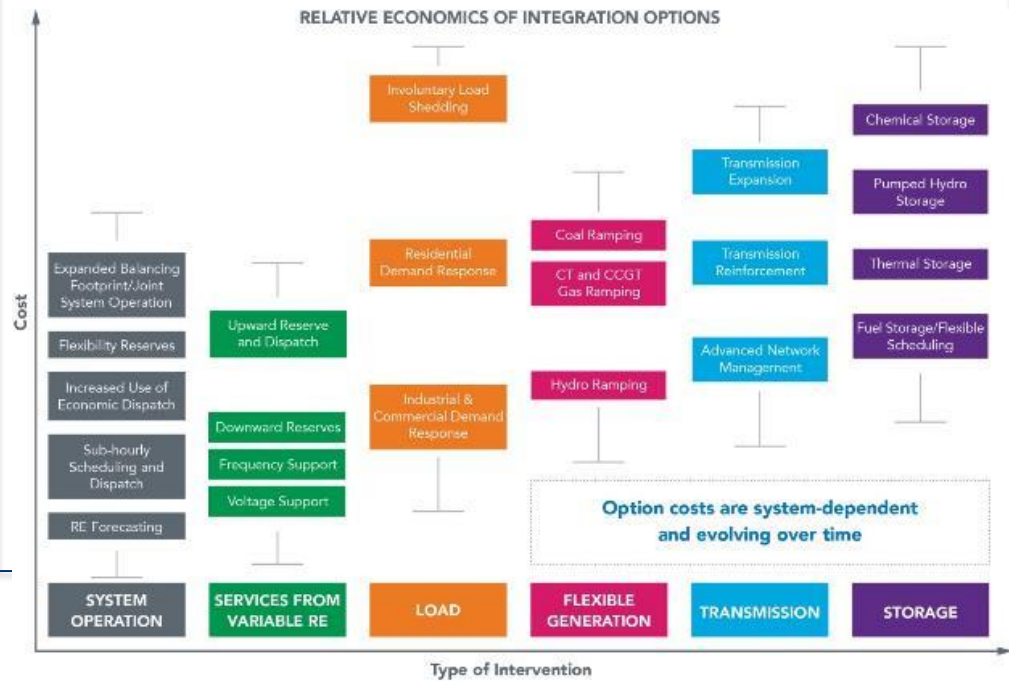

Two Examples of Potentially Cost Effective Storage Applications

What type?

Operating Reserves

Shorter duration

(<1 hour)

- Regulation reserves to balance short-term variability
- Fast frequency response to replace lost inertia

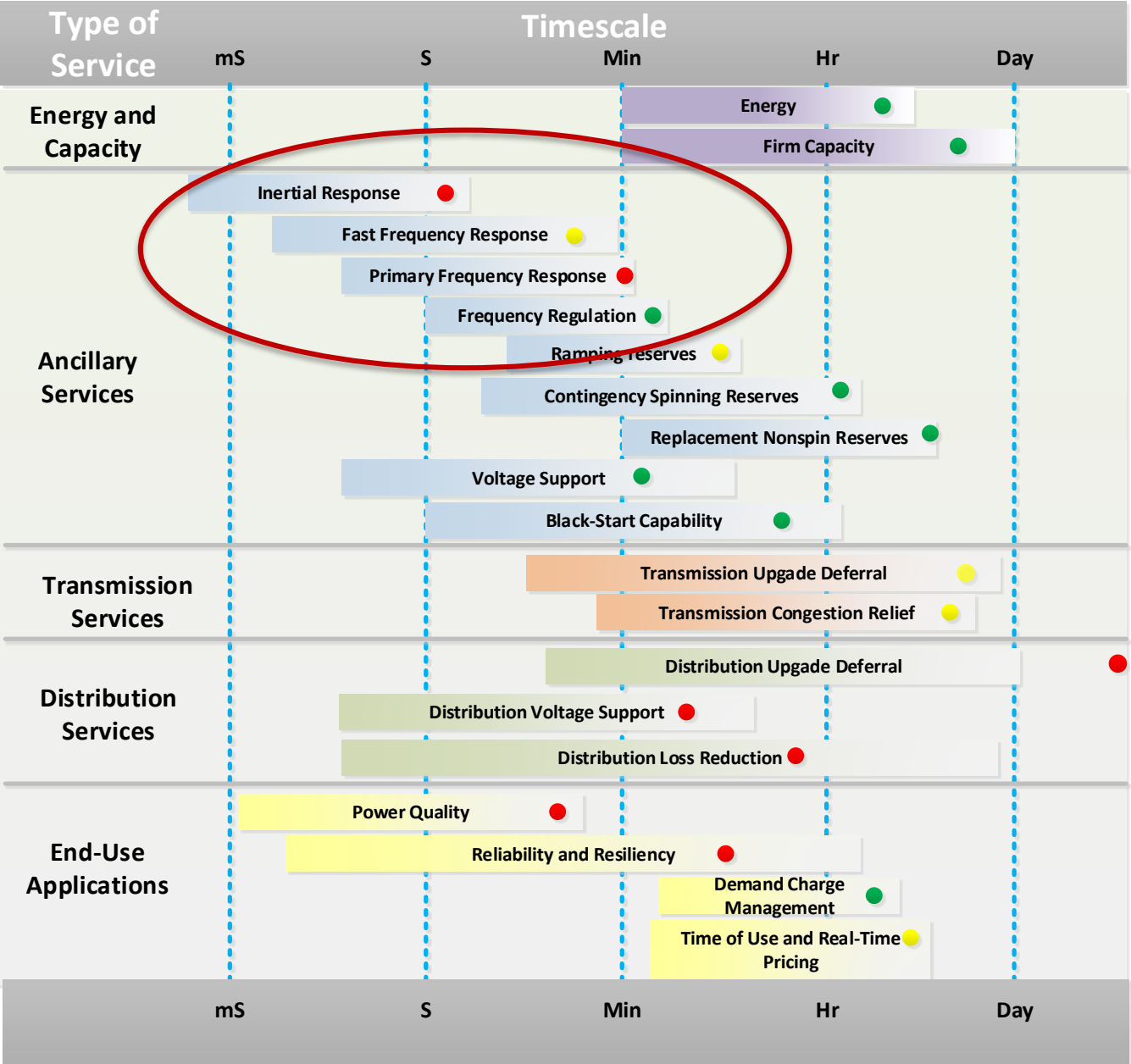

Two Examples of Potentially Cost Effective Storage Applications

What type?

Peaking Capacity

Longer duration

(>1 hour)

- Peaking capacity resource
- Energy shifting to recover curtailed RE, arbitrage prices
- Can also provide transmission services

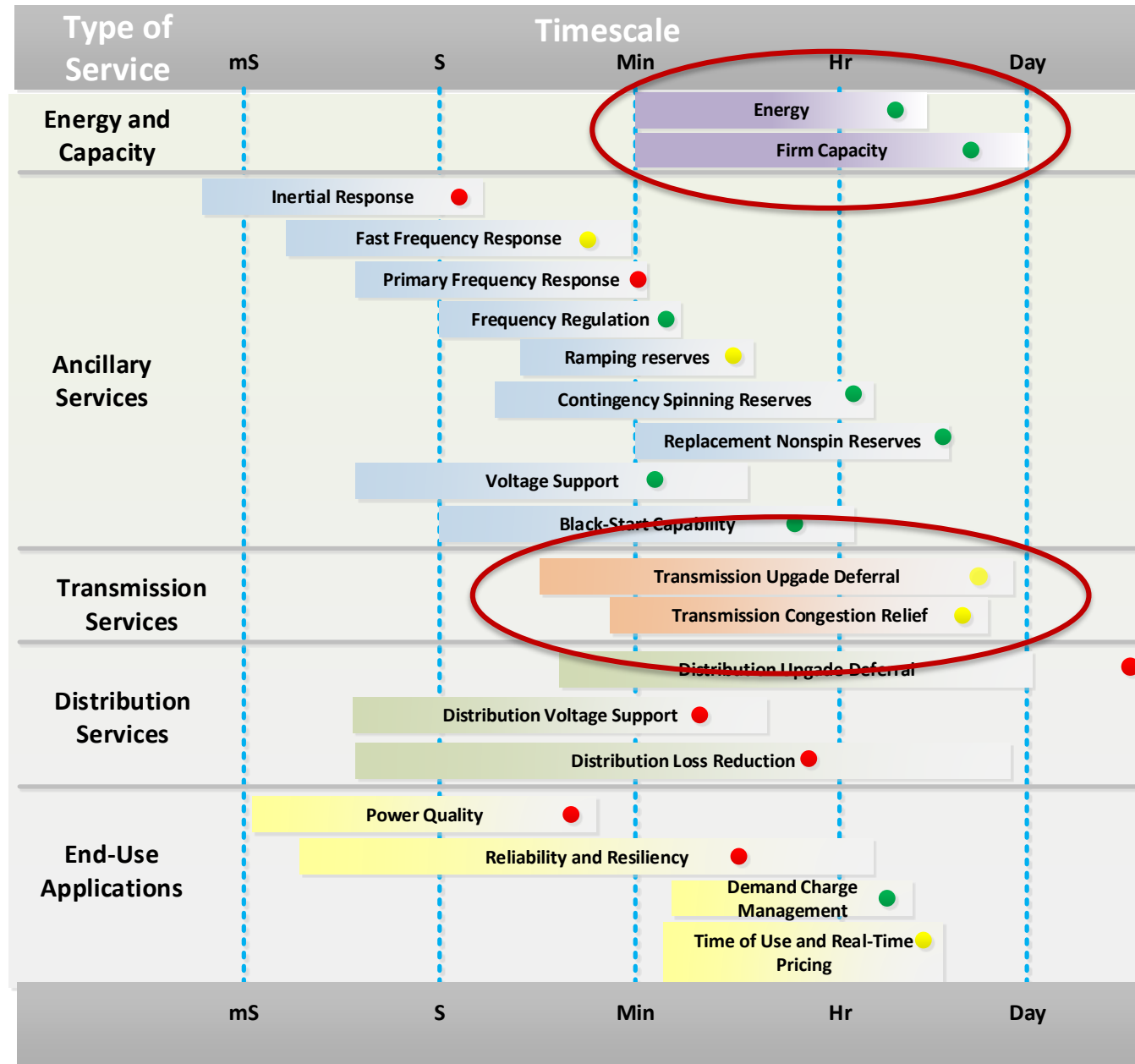

Battery storage for the provision of operating reserves

Early Deployment of Batteries for Reserves

- Significant deployment for frequency regulation (regulating reserves/ secondary frequency response)
- Often most cost effective early application
 - Short duration requirements
 - High utilization of storage assets

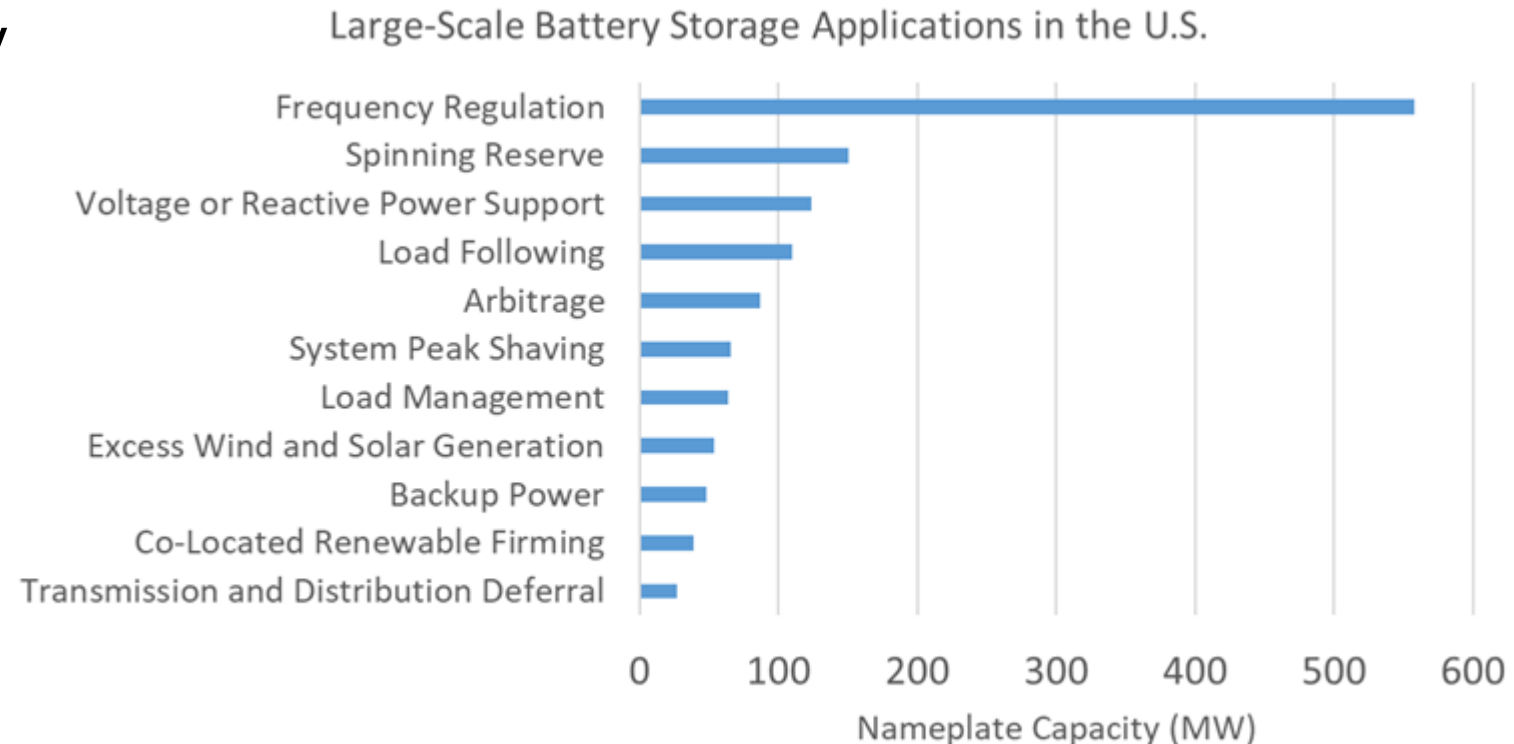

Operating Reserves Represents the Ability to Increase or Decrease Output Based on Grid Requirements

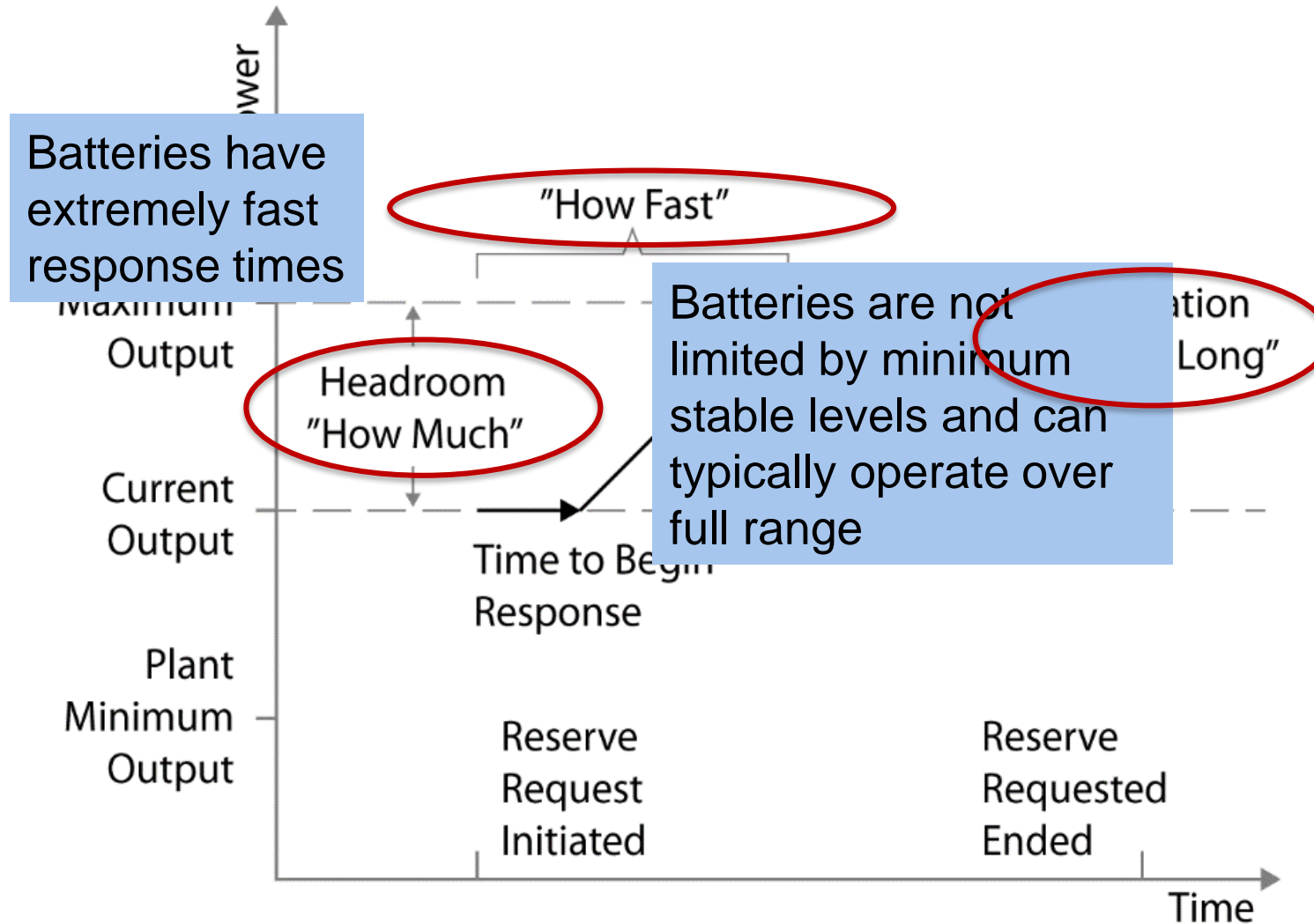

Batteries are limited by stored energy, so shorter duration devices may not be able to provide long-duration reserve services such as replacement reserves

Regulating Reserves

Why batteries?

Operating Reserves

- Responds to events (e.g., large generator faults) that can result in decreased frequency
- Operates during normal operations to respond to normal short-term variations in supply and demand

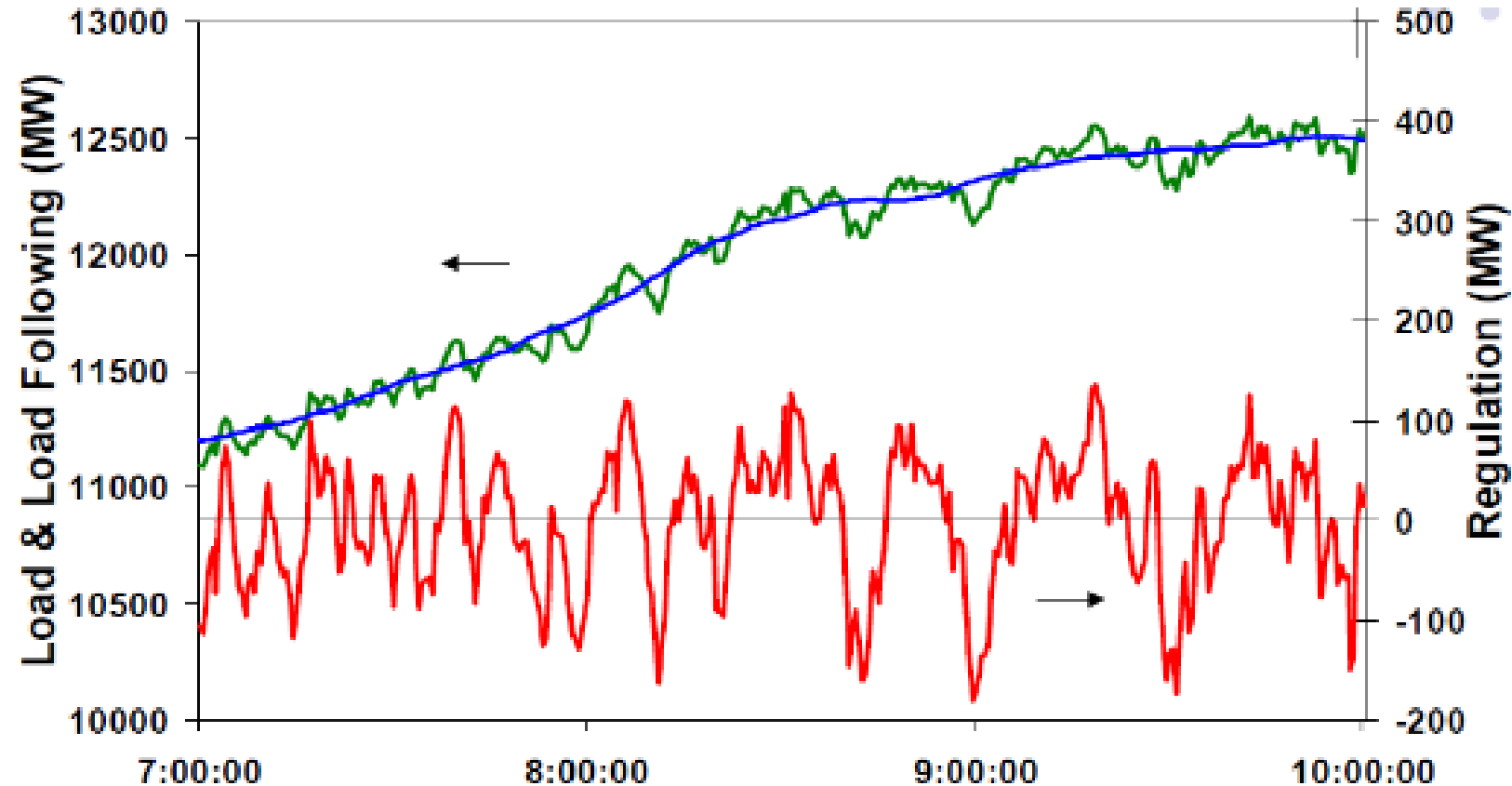

Why Batteries for Regulating Reserves?

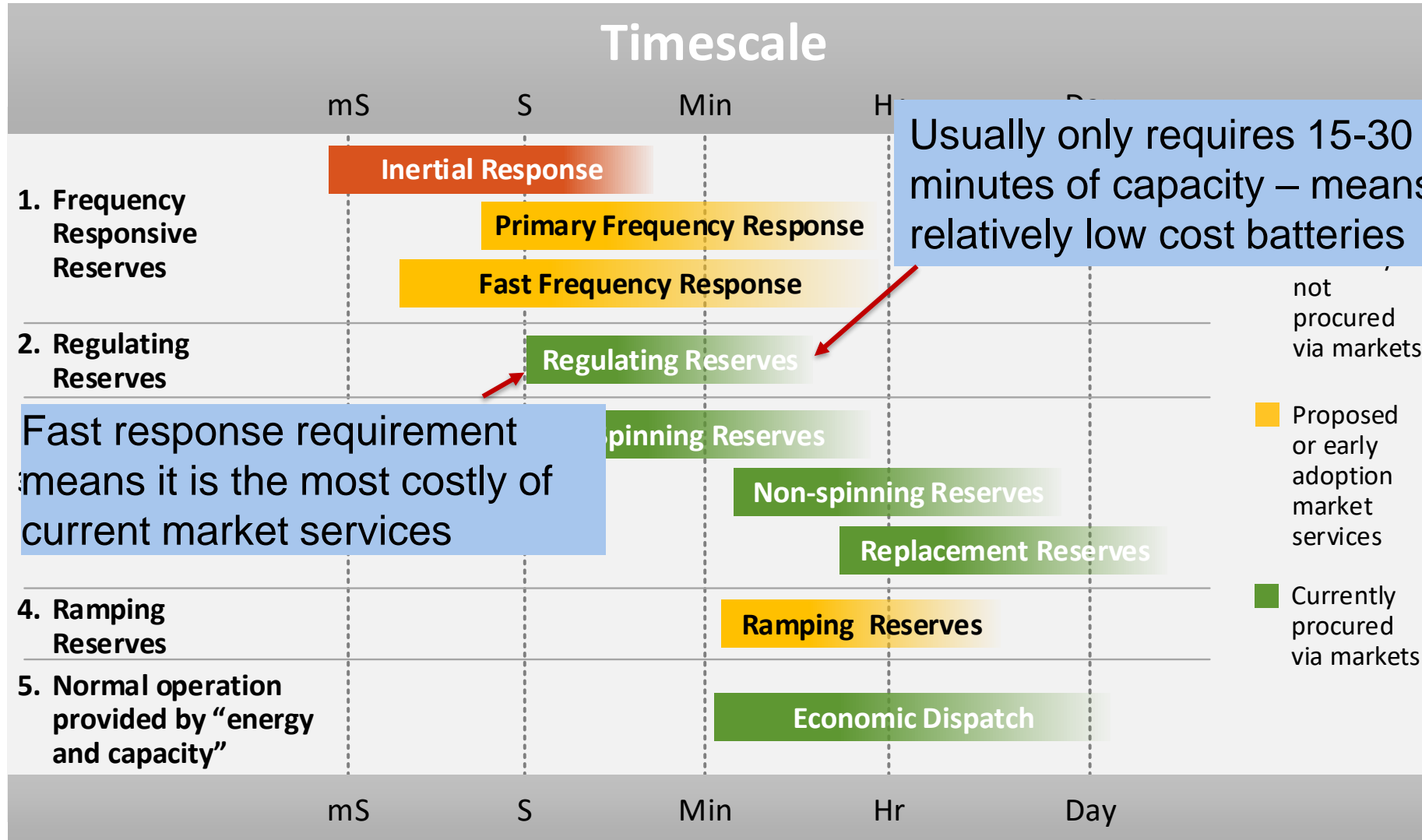

Batteries Have the Flexibility to Continuously Provide Upward and Downward Regulation

Why batteries?

Operating Reserves

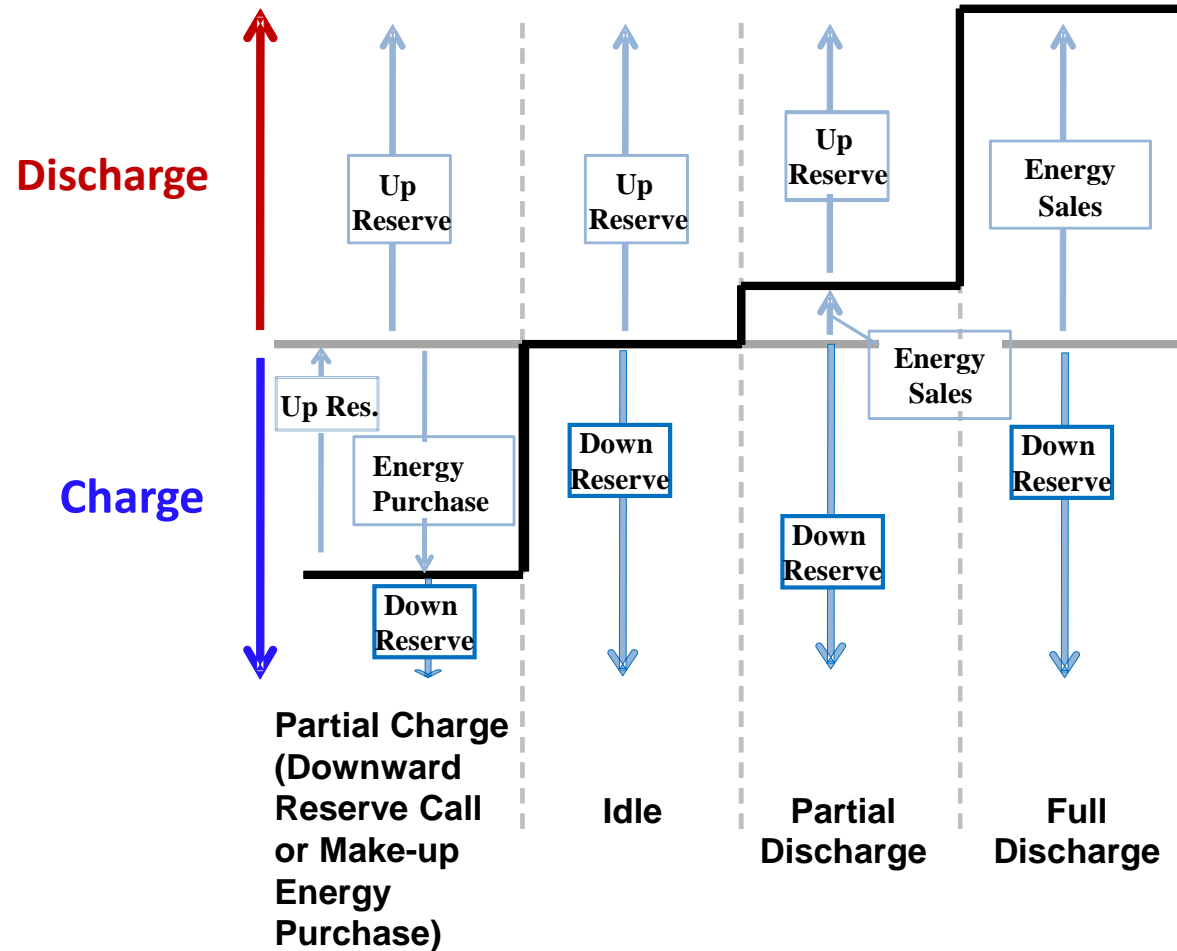

Energy storage typically has a larger operating range for provision of regulating reserves than thermal generation.

Impact of Increasing Amounts of Renewable Energy on Reserve Requirements?

How much?

Operating Reserves

- More variable RE could increase the need for various reserves, including regulating reserves
 - BUT ... integration studies show a relatively small increase in operating reserve requirements as solar and wind are added
- For example, regulation reserve requirements have decreased in Texas as wind penetration has increased

There is also competition for the provision of operating reserves from other sources, including curtailed wind and solar and demand response

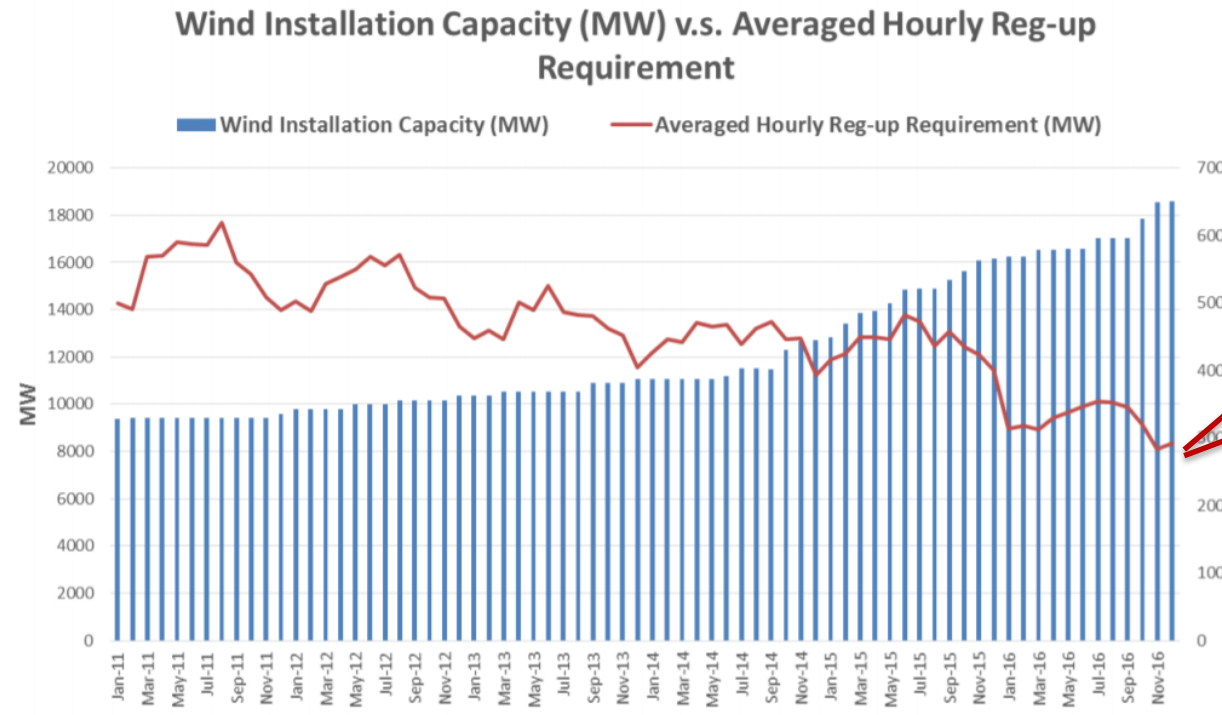

Other Reserve Services? Increasing Interest in Frequency Responsive Reserves

How much?

Operating Reserves

- Something will need to replace inertial response and primary frequency response (PFR) from synchronous generators
- Inconsistent terminology, but “fast frequency response” captures the ability of resources (including storage) to measure and rapidly respond to deviations in frequency.
- FFR could replace some of the need for inertial response.

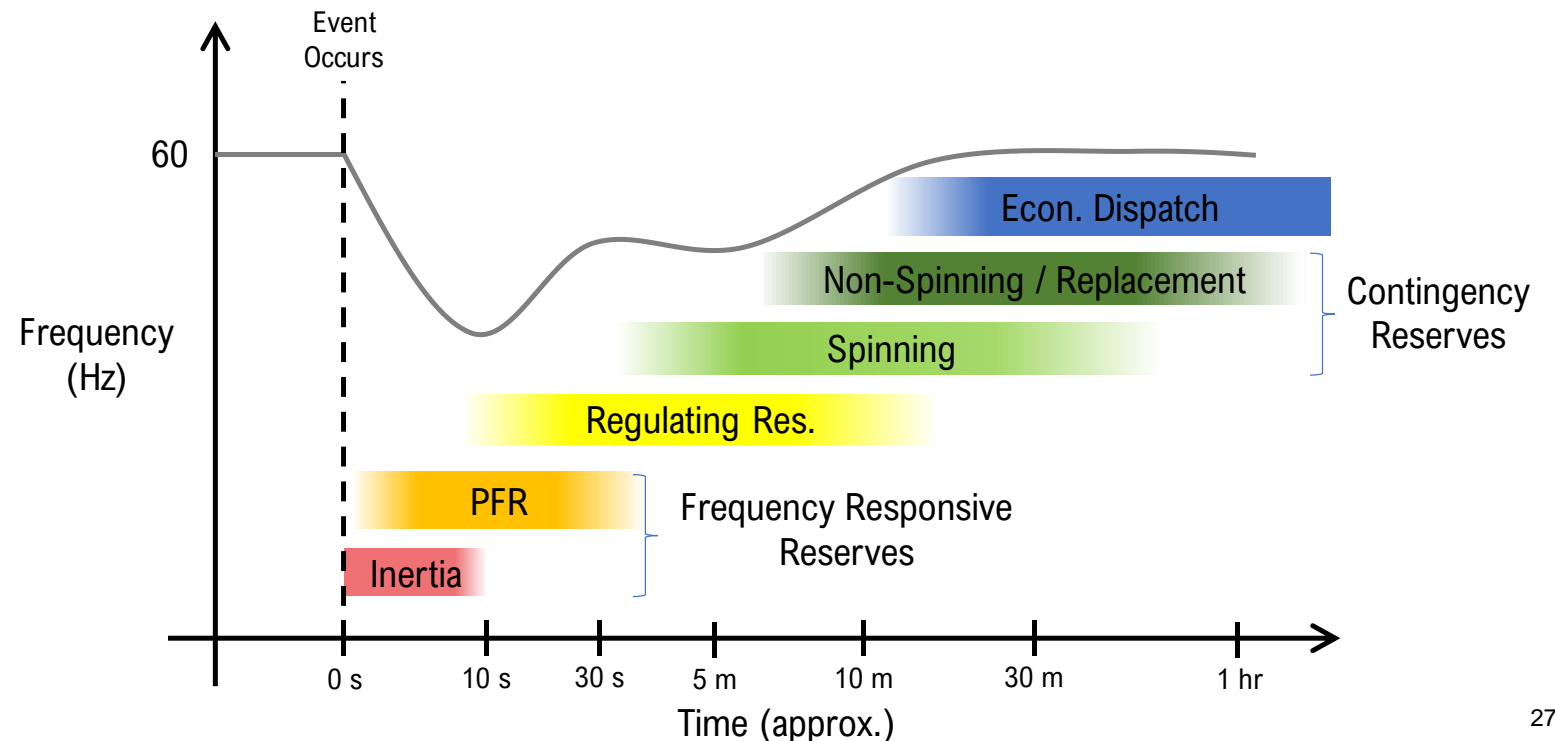

Example: Fast Frequency Response from Energy Storage

How much?

Operating Reserves

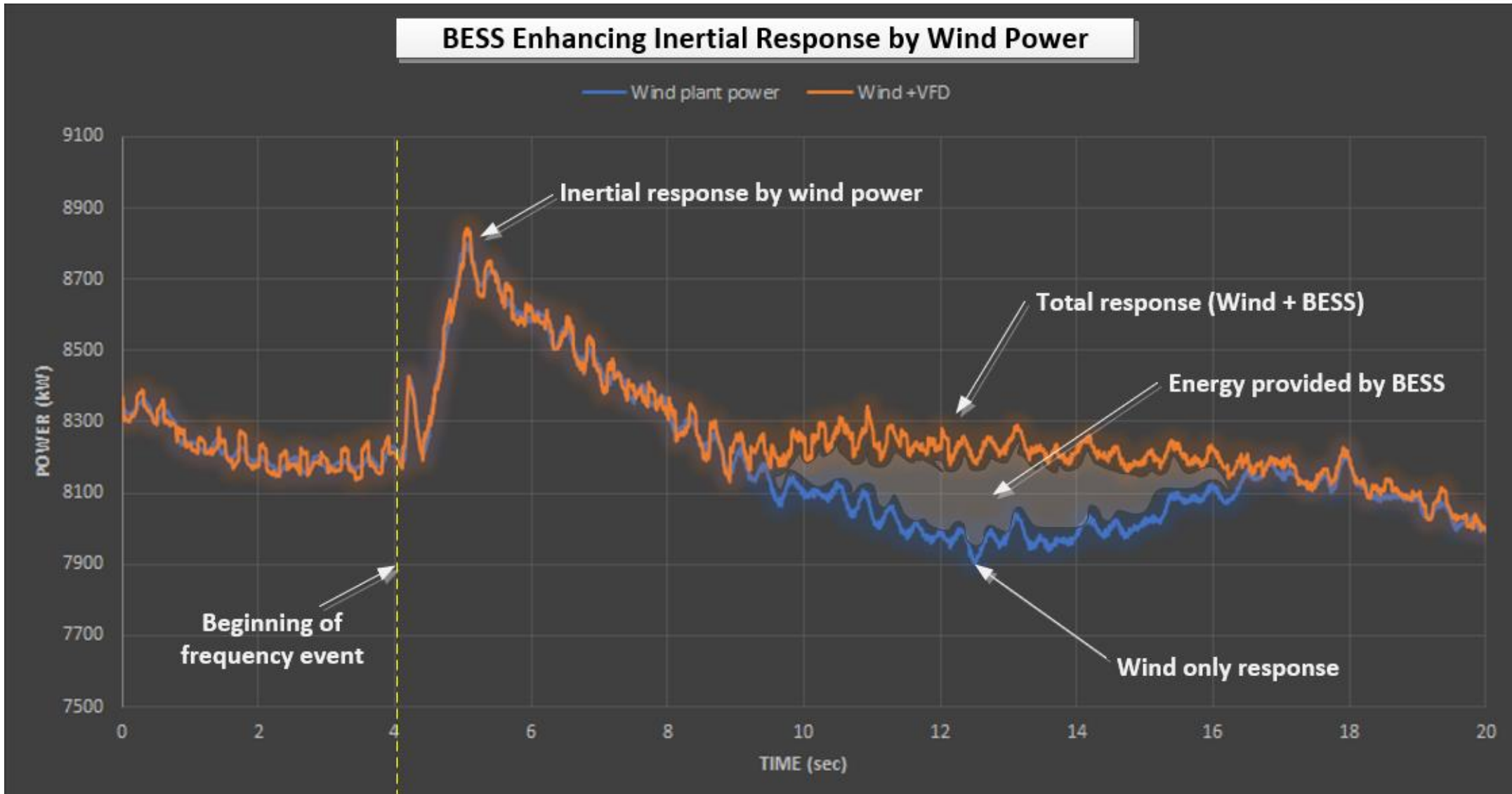

Source: Gevorgian, Burra, Morjaria (2018) <https://www.nrel.gov/docs/fy18osti/71551.pdf>

How much operating reserve do we need?

- Limited need for high value reserves.
- Total market for regulating reserves in all U.S. RTO/ISO markets is ~2.6 GW.
- Already have ~700 MW of new battery storage
- Increased competition from DR and other sources
- What's the next big thing?

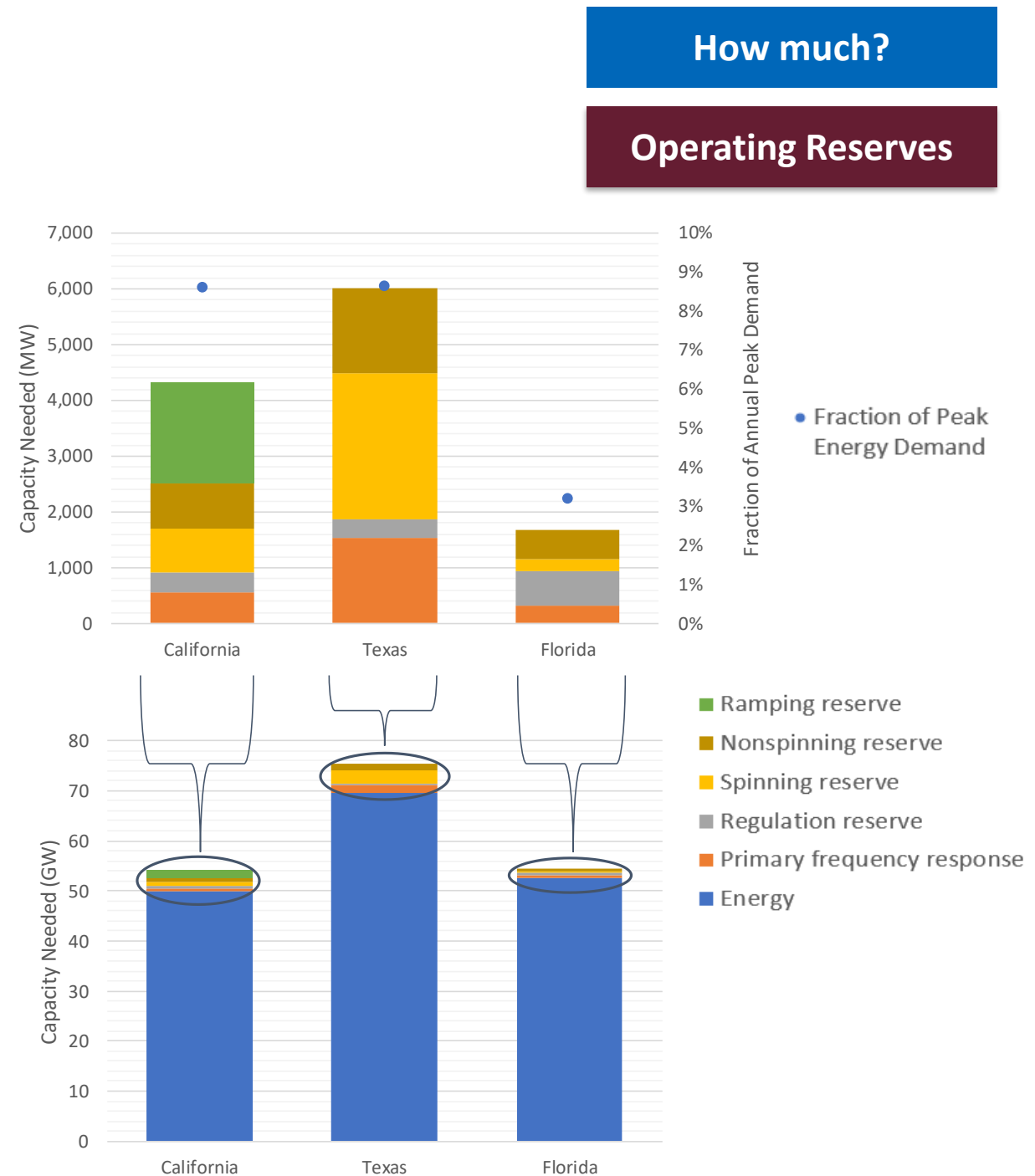

Battery storage peaking capacity

Recent Focus – Peaking Capacity

- Aging peaking capacity in the U.S.,
- Other growing economies with increasing peak demand (air conditioning, climate impacts)

Installation dates of U.S. peaking capacity (non CHP CT, IC, oil/gas steam)

Significant peaking capacity now over 40 years old

Over the next 20 years, we would expect about 152 GW of peaking capacity to retire in the U.S.

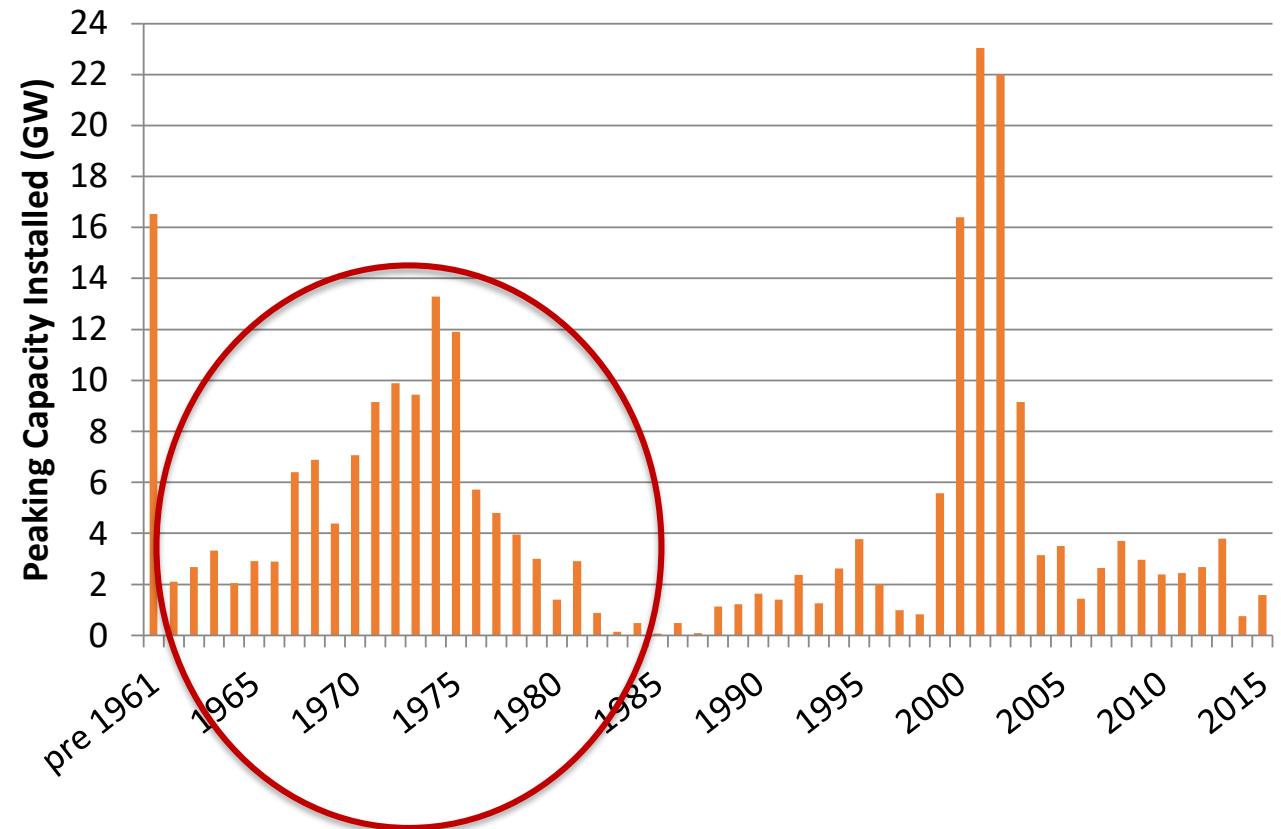

Challenge of Comparing Storage to Conventional Peaking Capacity: 1) Capacity Credit/Capacity Value

How much?

Peaking Capacity

Capacity credit/capacity value reflects the ability of a generator to be available during periods of highest system stress. This is typically during the periods of peak demand. Analysis must determine the energy capacity (hours) needed to provide an alternative to conventional peaking capacity.

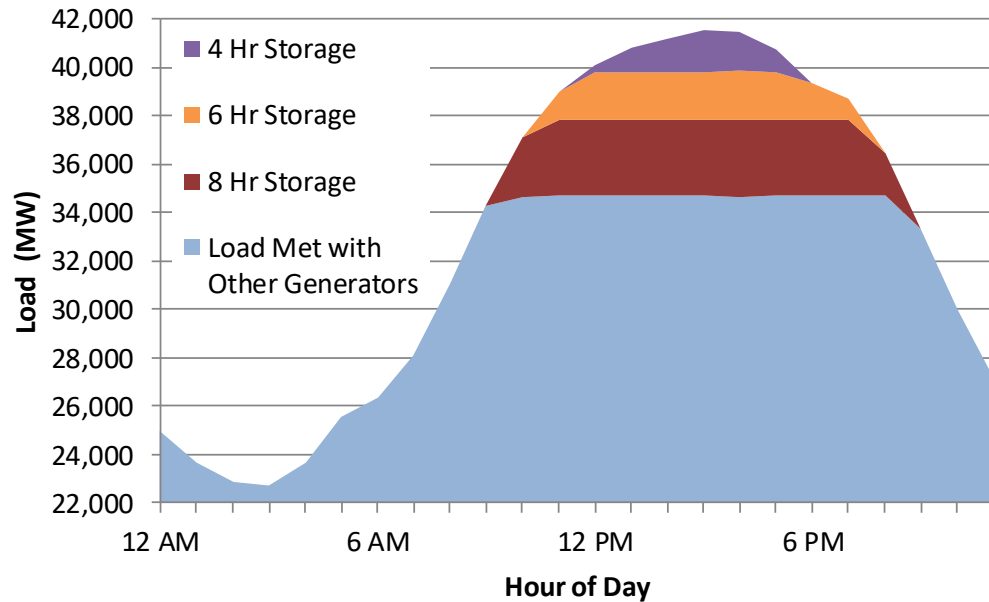

Florida has narrow peaks well suited for shorter duration storage

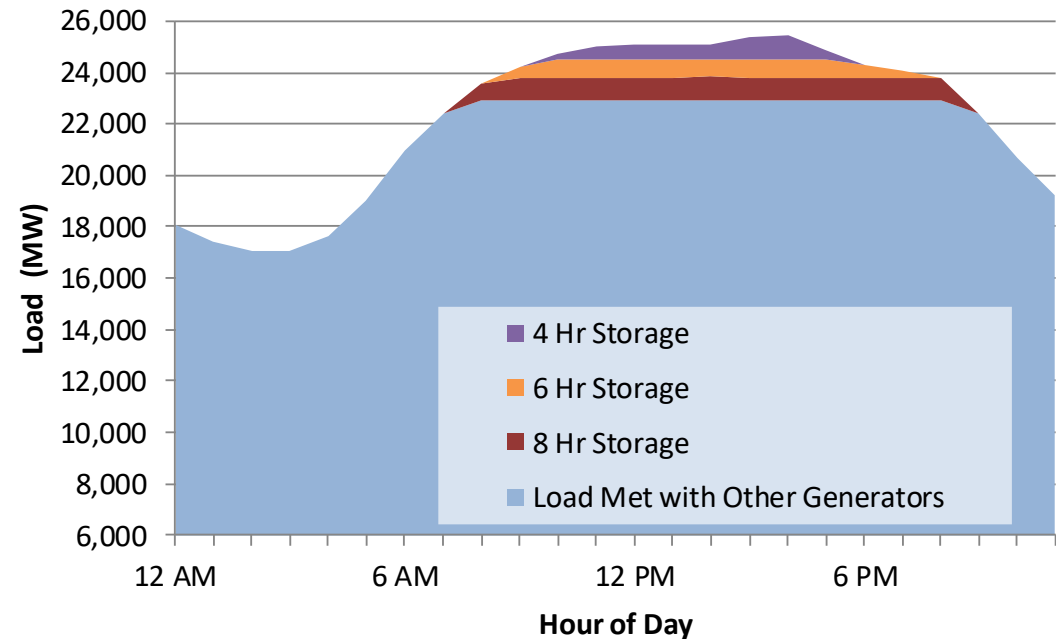

New York has longer peaks so requires longer duration storage

Challenge of Comparing Storage to Conventional Peaking Capacity: 2) Operational Value

How much?

Peaking Capacity

- Batteries and combustion turbines with the same power capacity may have substantially different operation in economic dispatch
 - Batteries and CTs typically have low generation capacity factor (<20%) but batteries may still have higher capacity factors than CTs
 - Batteries may have different operational profiles, acting to avoid thermal generator starts. This value is difficult to capture, and is uncompensated in ISO/RTO markets.
- LCOE vs LCOS may be a poor comparison metric

Simulations of storage in production cost models often show short spikes of battery output to avoid thermal plant spikes and address ramping events

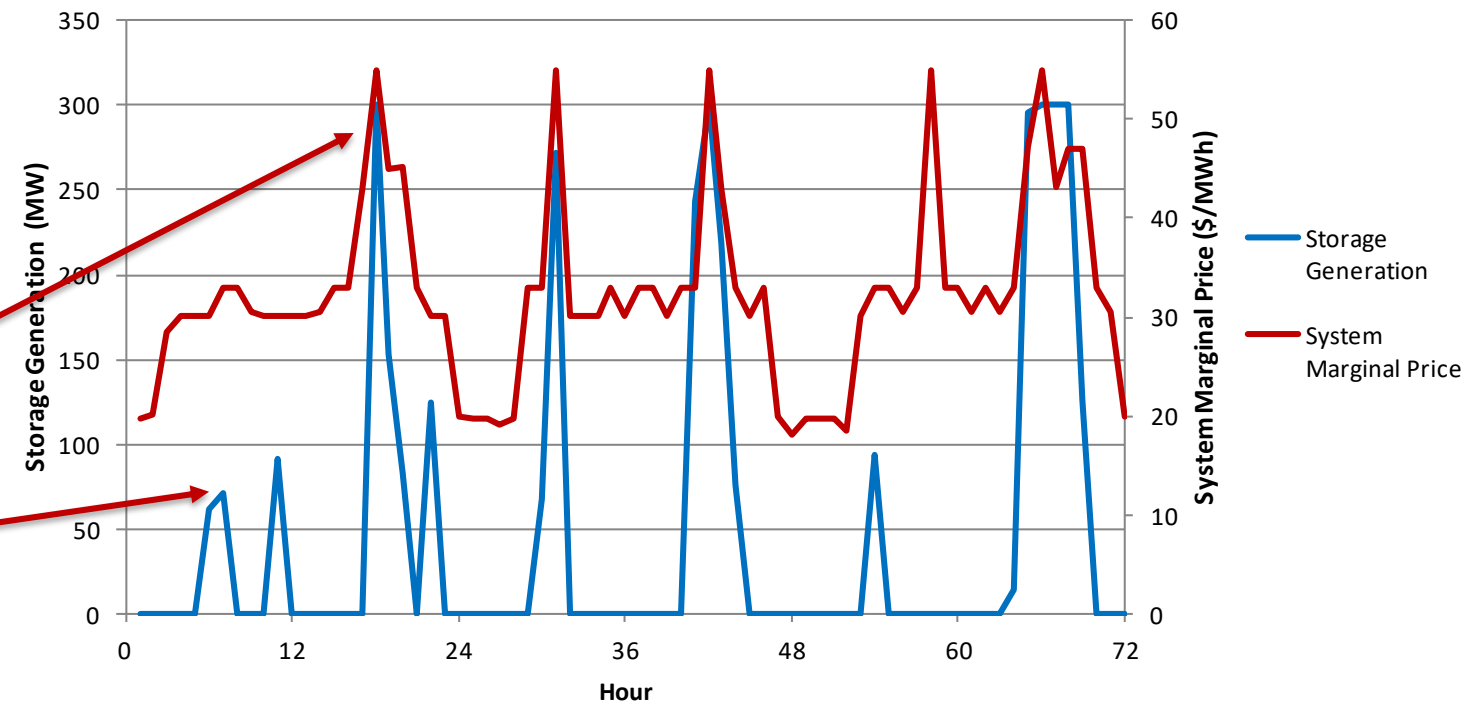

When?

Peaking Capacity

So How Cheap Does Storage Have to Be?

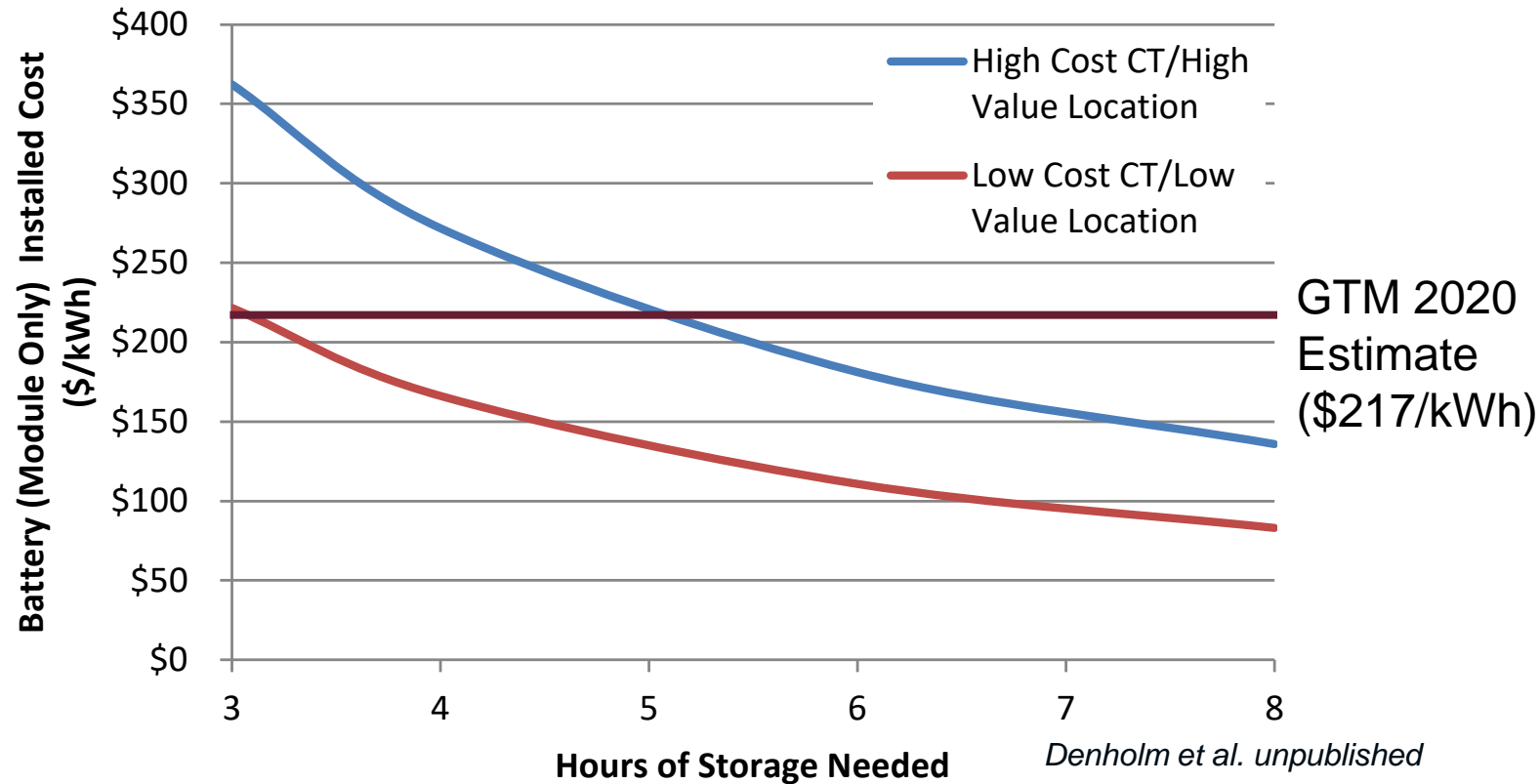

We are nearing a tipping point for 4-hour storage providing capacity services – but how big is this market?

Potential for Storage as Peaking Capacity in Today's Grid

How much?

Peaking Capacity

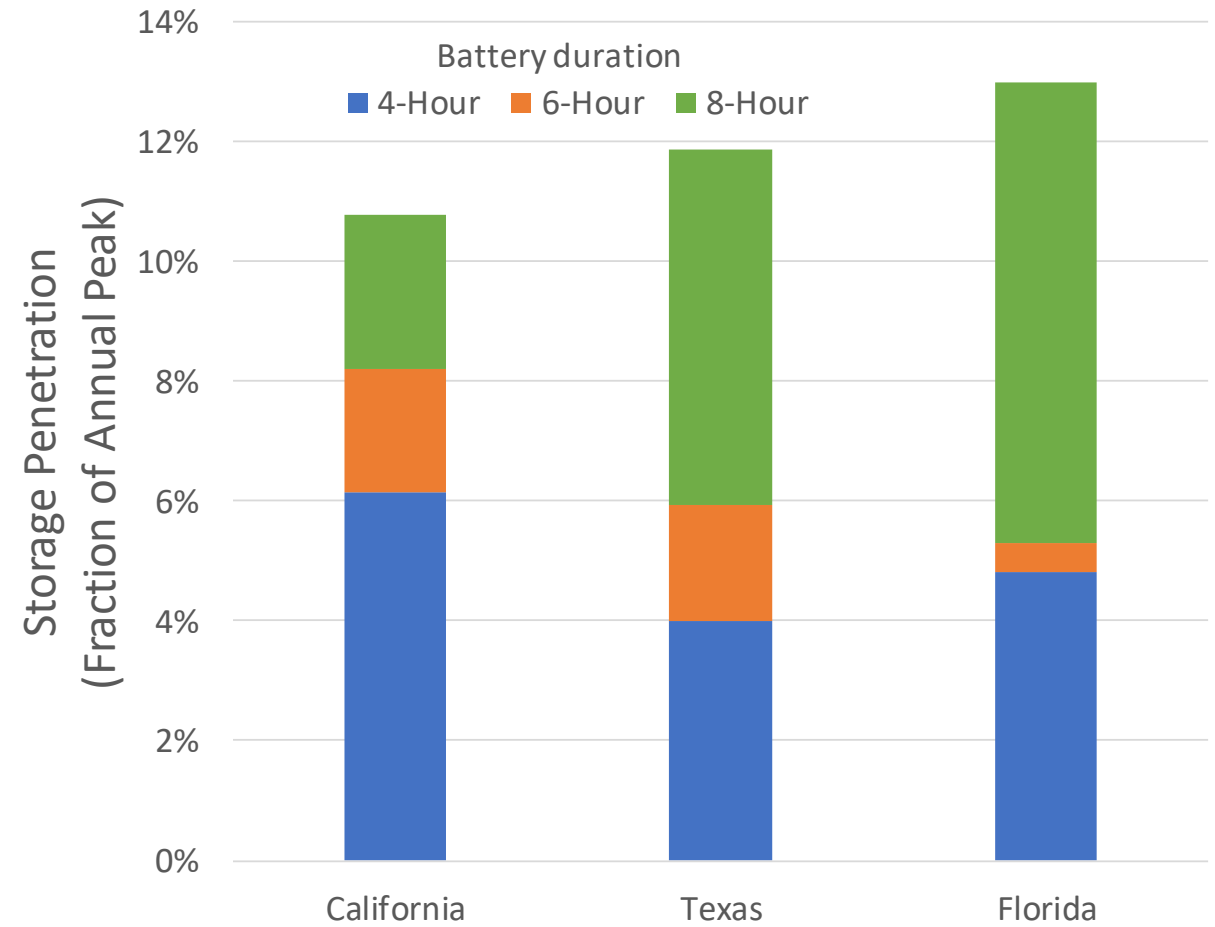
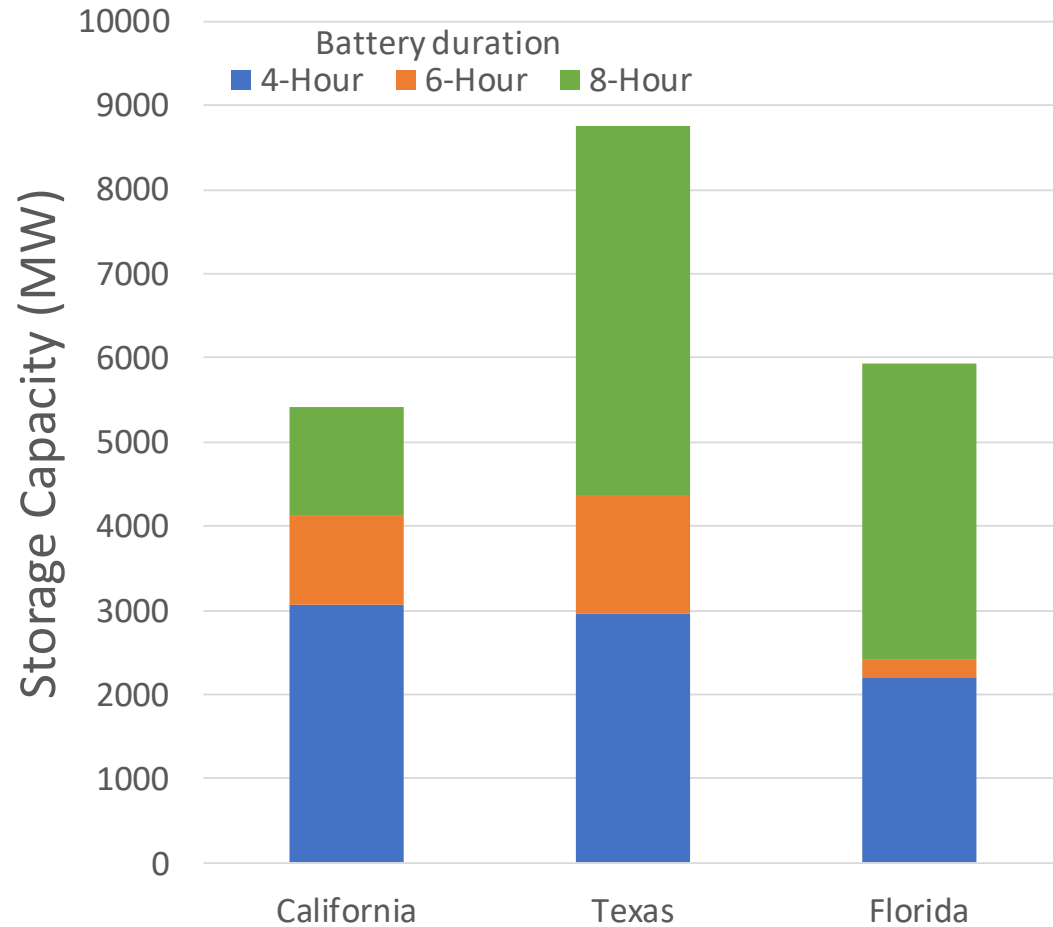

Higher penetrations of RE will change the economics of battery storage

How much?

Peaking Capacity

- Renewable energy can lower the cost of using batteries for peak demand reduction

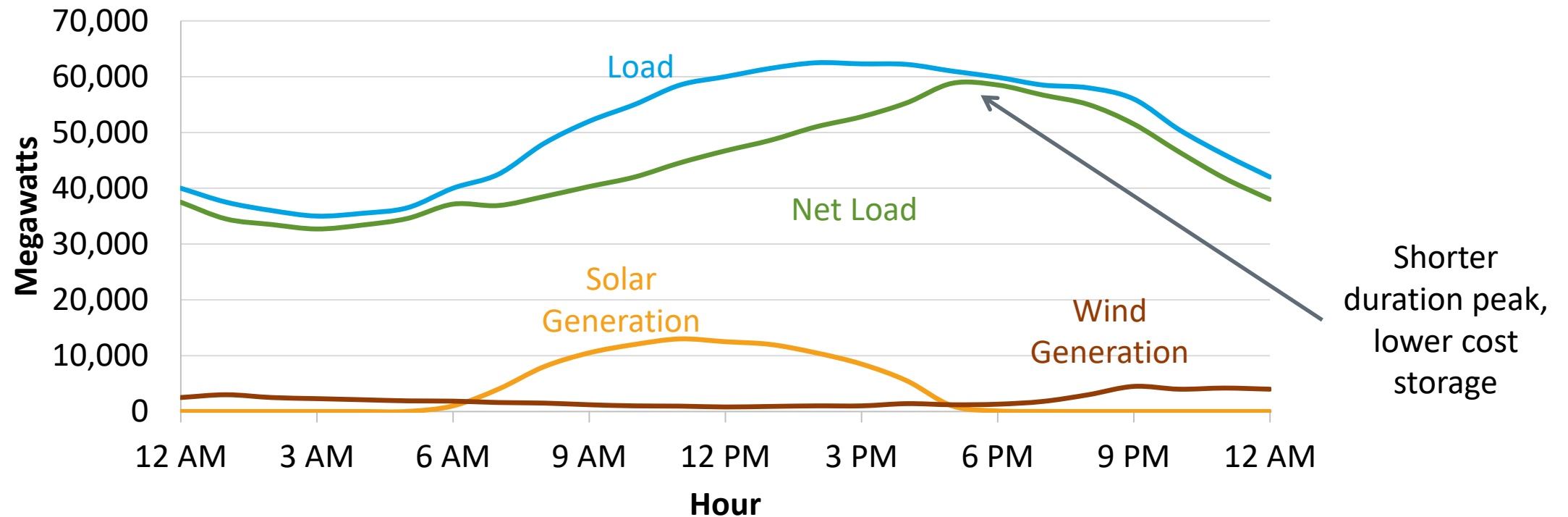

Some power systems are nearing a tipping point for 4-hour storage providing capacity services instead of conventional generators

How much?

Peaking Capacity

How Do Renewables Affect This?

Zero PV

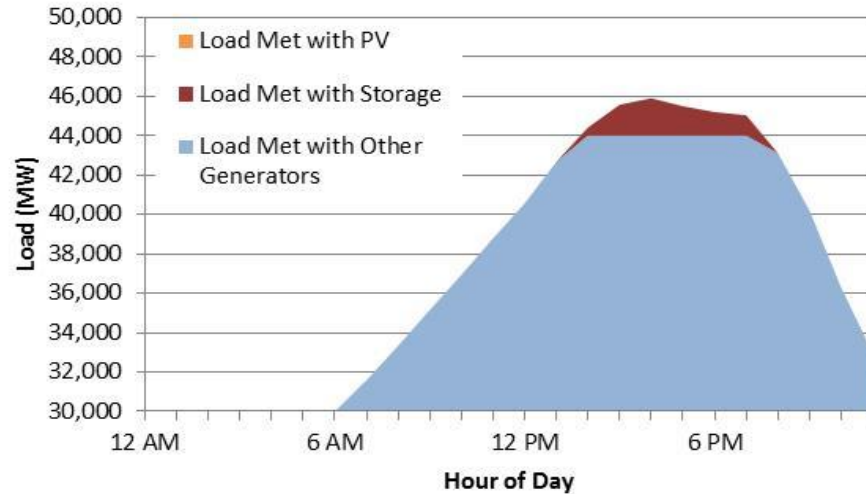

5% PV

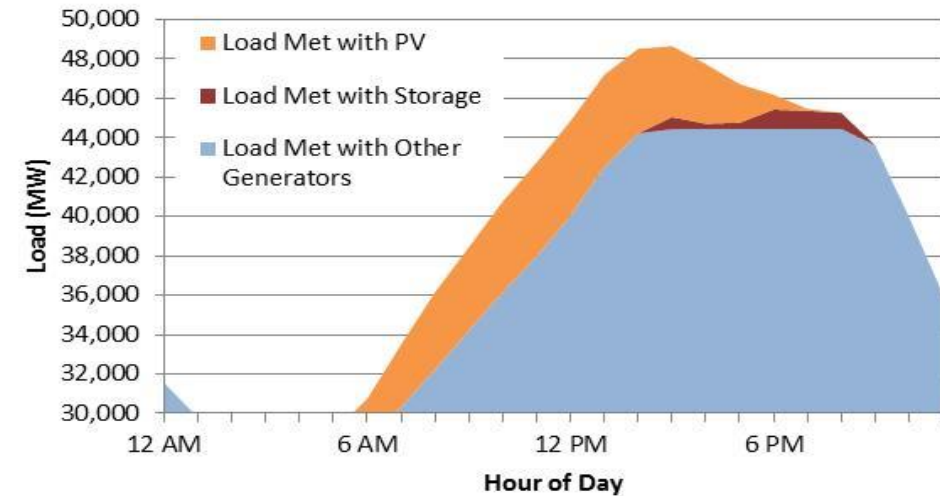

10% PV

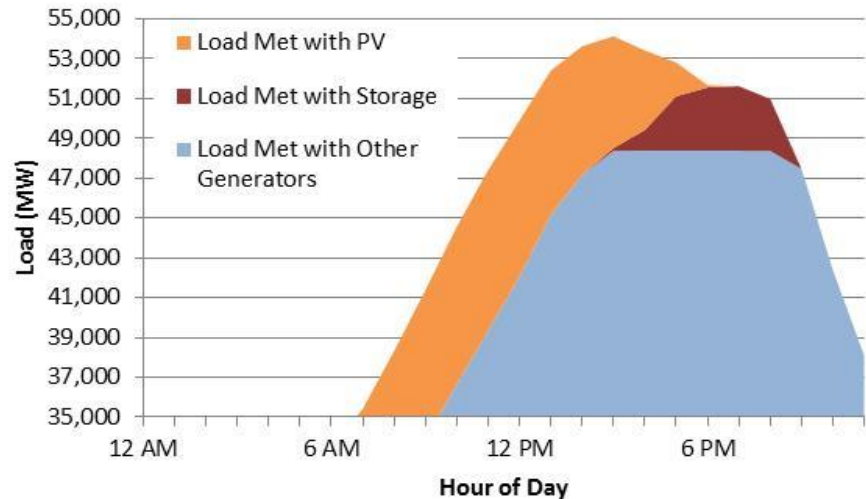

With increased PV penetration, the capacity value of PV decreases while the capacity value of storage increases

Impact of PV on 4-Hour Storage Potential in California

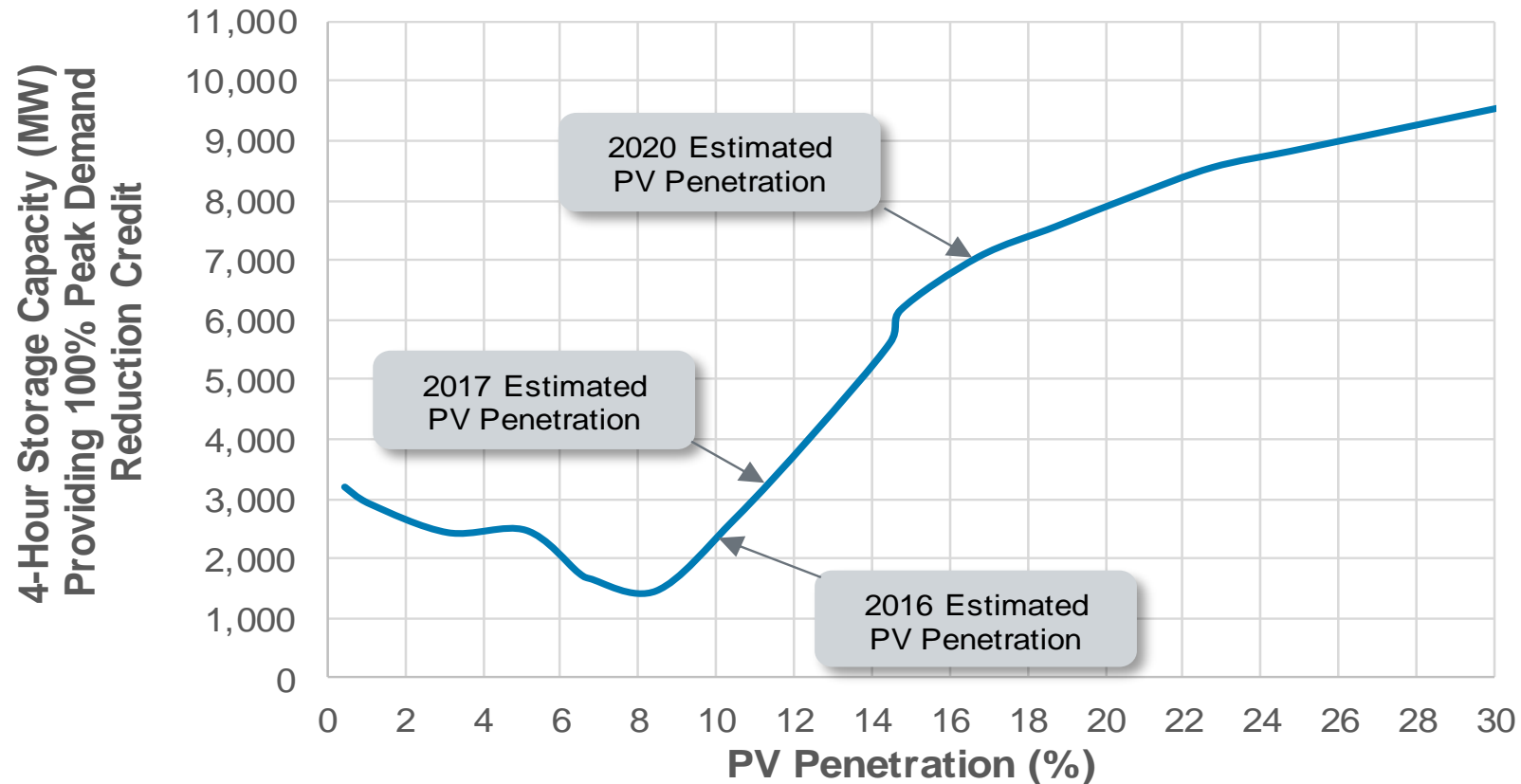

Denholm and Margolis 2017

Consistent correlation of storage capacity with PV. Very limited correlation with wind in the U.S.

Where should storage be deployed?

Where should storage be deployed?

1. At the load site?
2. Near remote renewables?
3. Coupled with other generation technologies (e.g., solar + storage, gas + storage)?

Location 1: Within Load Centers

- Allows replacement of peaking capacity in congested regions
 - Reduced siting challenges of thermal generation
 - Defers investment in transmission and distribution
 - Avoided T&D losses
 - Scalable



Southern California Edison hybrid battery storage, gas turbine peaker system

Location 2: Co-Located with Remote RE Resources

Where?

Example: Interaction Between Storage and Transmission in the Western United States

- Best wind resources are not close to major population centers
- Significant transmission capacity will be needed
- Transmission typically operated at relatively low capacity (based on capacity factor of wind)

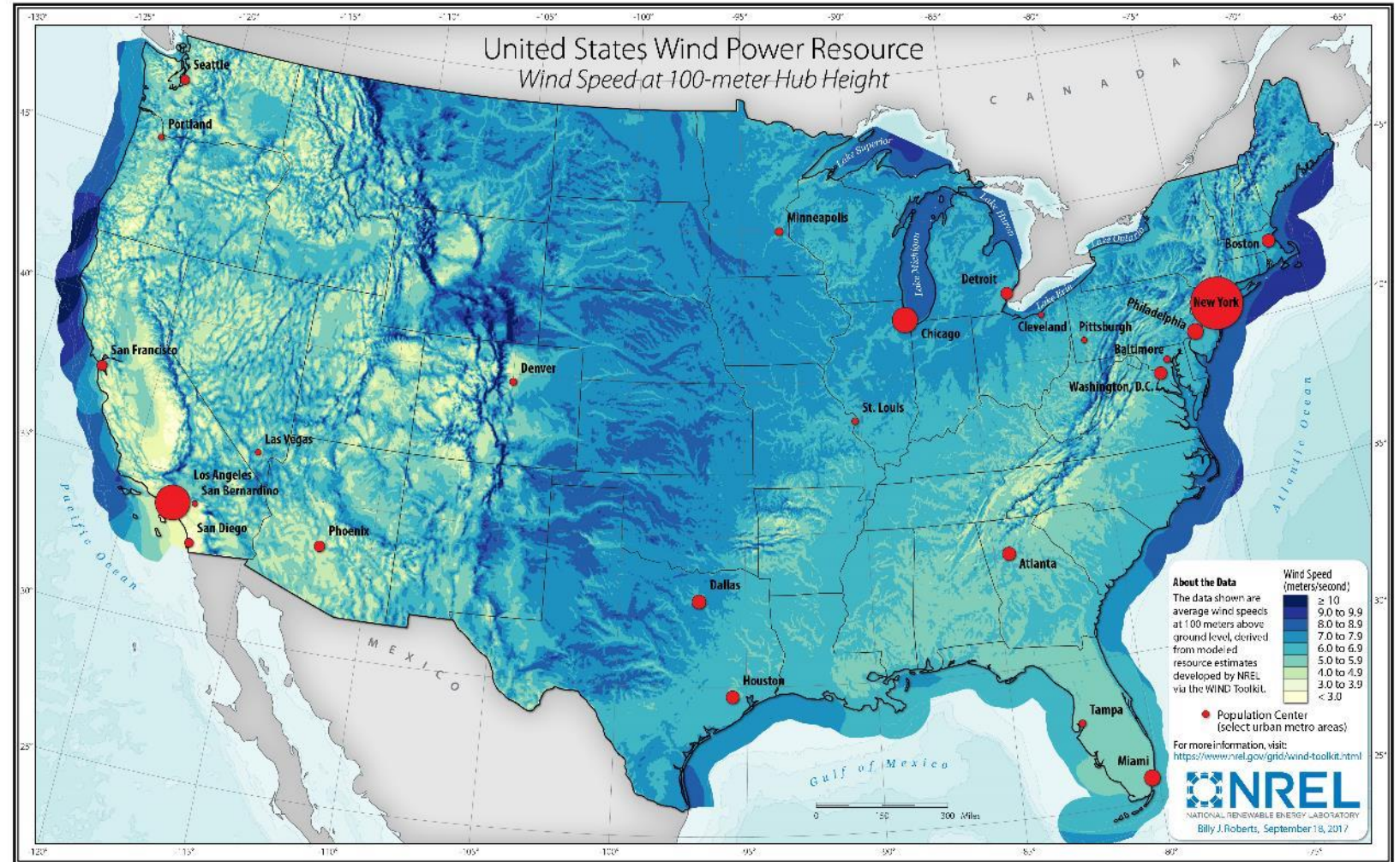

Storage can reduce transmission requirements

Where?

Capacity Factor of this 200 MW of transmission is about 10%

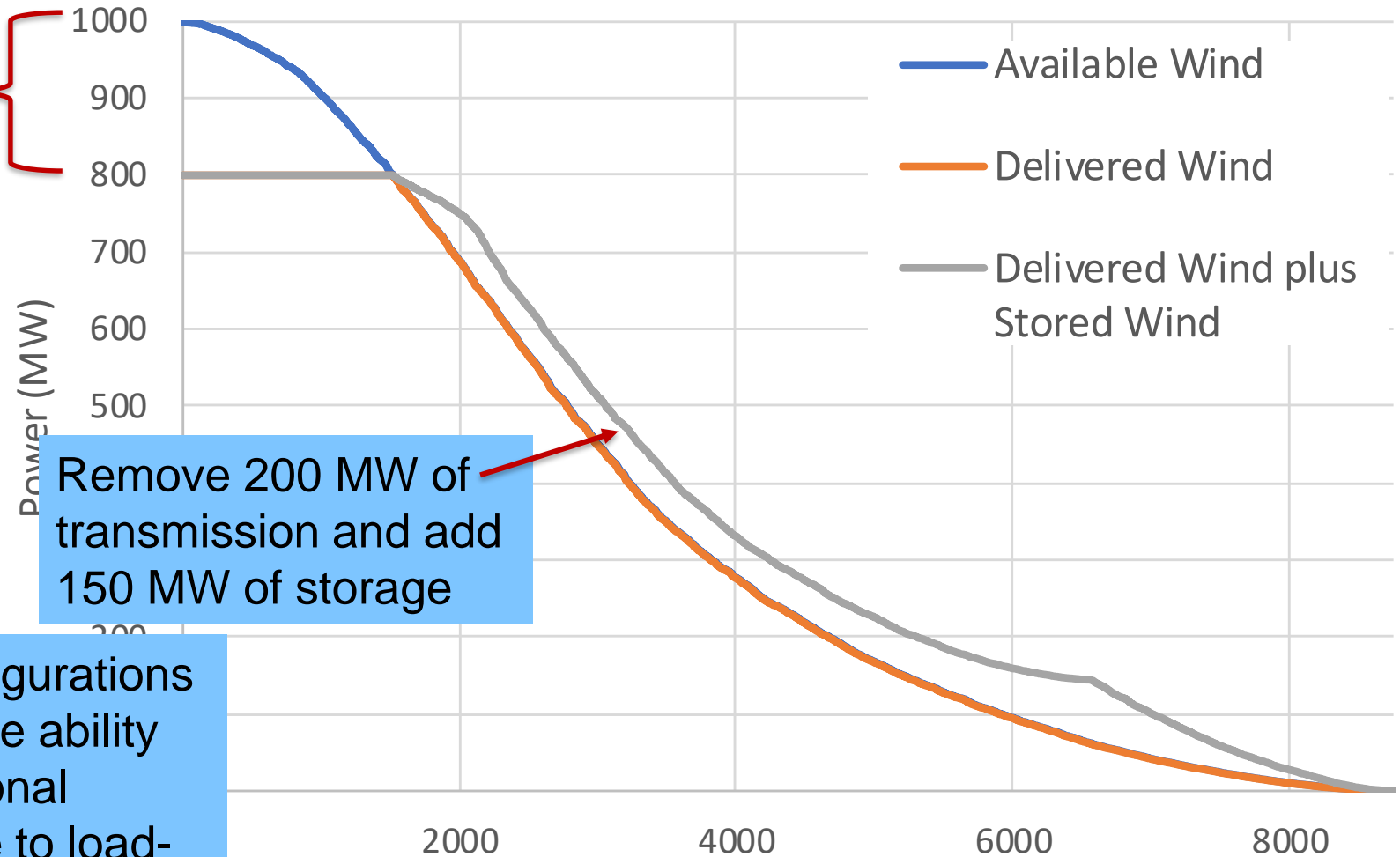

Remove 200 MW of transmission and add 150 MW of storage

When evaluating such configurations it is important to consider the ability of storage to provide additional services. But also compare to load-sited storage.

Duration curve for 1000 MW of wind in Texas

Location 3: Integrated with Renewable Generation

- Enhance unit flexibility
- Reduce costs through shared componentry
- Provide streamlined acquisition for off-takers
- Can lead to inefficient levels of storage if required with all variable RE (ignores benefits of geographic diversity)

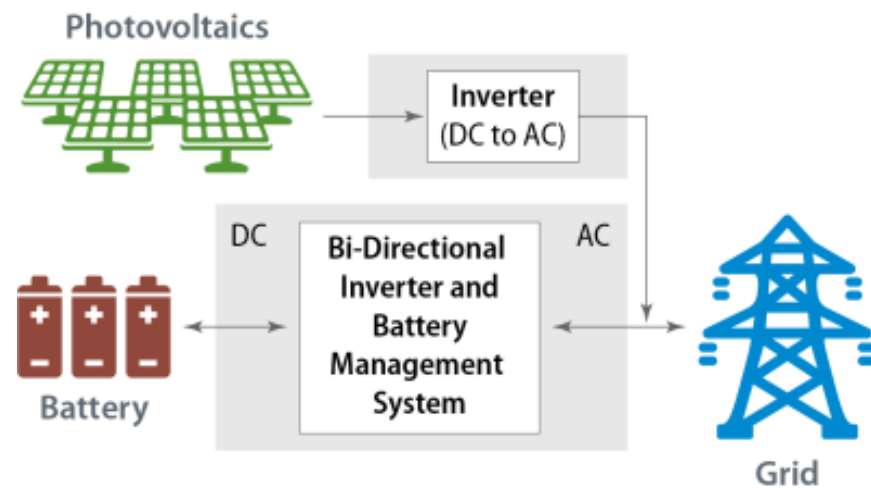

AC-coupled (flexible charging)

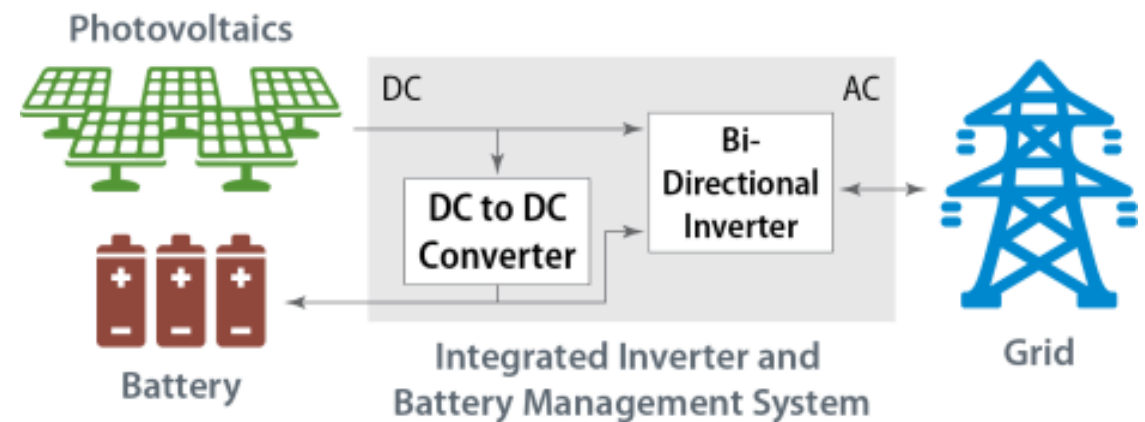

DC-coupled (flexible charging)

Siting Can Change Relative Value of Various Applications

Where?

Which location is best?

...It depends!

Analysis is needed to optimize the costs and benefits of various storage siting options

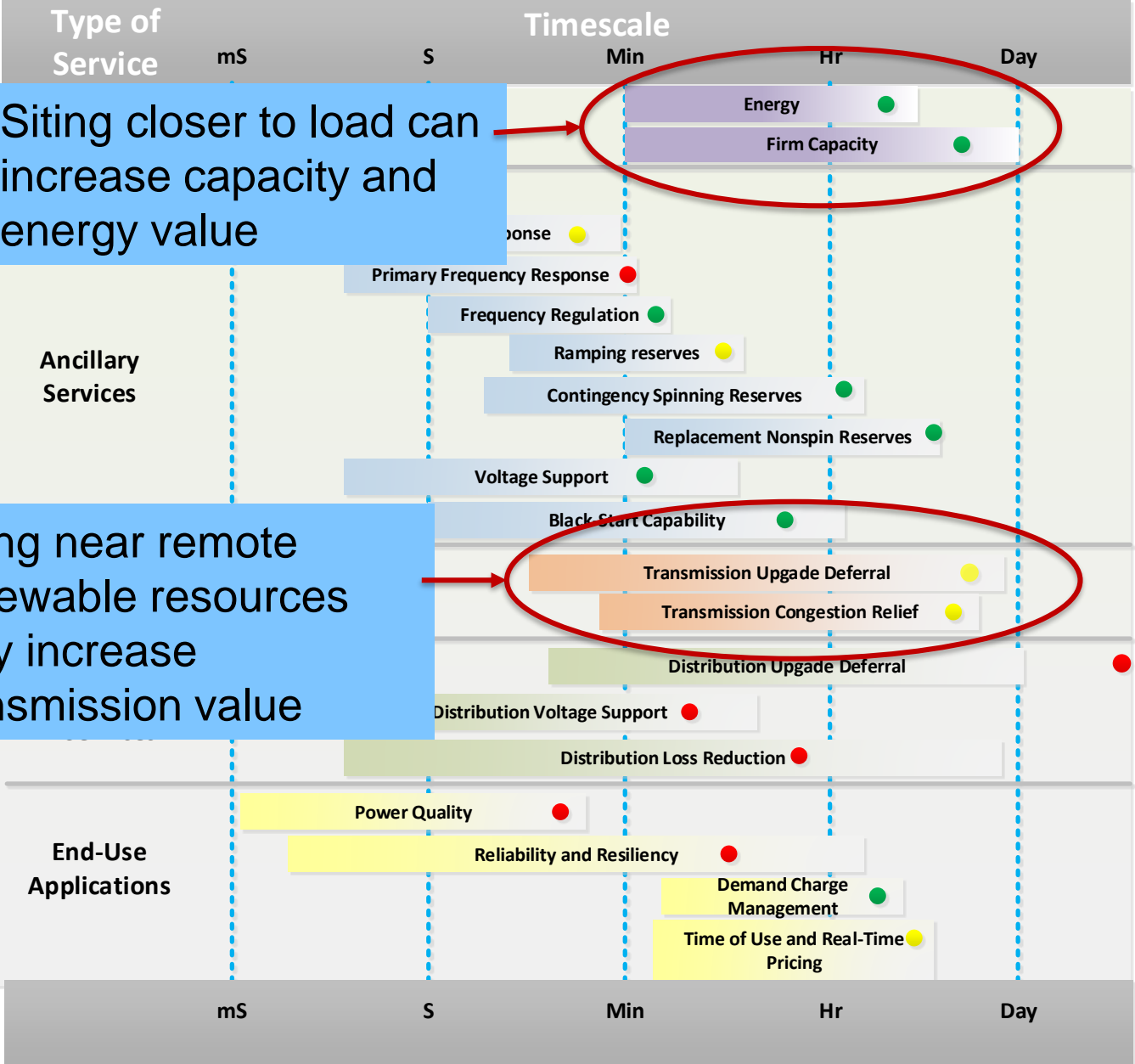

Siting closer to load can increase capacity and energy value

Siting near remote renewable resources may increase transmission value

Conclusions / Opinions

1. Stand-alone “renewable integration” applications of energy storage are typically neither needed nor cost effective in most grids.
2. Ancillary services (regulating reserves) appears to be cost effective for a few storage devices, but with limited market size.
3. When properly scheduled, long-duration (several hours of capacity) batteries provide an alternative to combustion turbines for meeting peak capacity requirements.
4. We are approaching a “tipping point” where storage provides a cost-effective alternative to conventional peaking capacity.
 - This application also needs to consider the energy arbitrage value of storage. Combining energy and capacity applications is key as the value of storage for energy arbitrage alone is relatively low and is unlikely pay for any existing storage technology/device.
 - RE will help accelerate the storage tipping point and increase the overall market size.
5. There is no easy “one size fits all” rules for where storage should be located. It is very application and grid-specific.
6. Careful analysis of storage is required to ensure it is sized and located properly, and that appropriate rules exist that can capture the value it can provide.

Thank you



NREL is a national laboratory of the U.S. Department of Energy, Office of Energy Efficiency and Renewable Energy, operated by the Alliance for Sustainable Energy, LLC.



Questions?

Webinar Panel



Paul Denholm

National Renewable Energy
Laboratory

Email: Paul.Denholm@nrel.gov



Jennifer Leisch

United States Agency for
International Development

Email: jleisch@usaid.gov

Greening the Grid

greeningthegrid.org

Email: greeningthegrid@nrel.gov

