



International Solar Alliance Expert Training Course

PV Technology: Solar Storage and End-of-Life Use & Recycling

In partnership with the Clean Energy Solutions Center (CESC)

Supporters of this Expert Training Series



This Training is an additional module and focuses on the issue of **Solar Storage and End-of-Life Use & Recycling**



- 1. Introduction: Learning Objective**
- 2. The Need for Energy Storage**
- 3. Solar PV combined with Storage Technology**
- 4. Solar PV combined with Storage examples**
- 5. Solar PV End-of-Life Management**
- 6. Batteries End-of-Life Management**
- 7. Conclusions**



1

Introduction: Learning Objective

Objective

- Explore solar storage technology options and the benefits and drawbacks of current storage options.
- Provide an overview of the end-of-life treatment of solar PV equipment combined with storage facilities, and potential development therein.

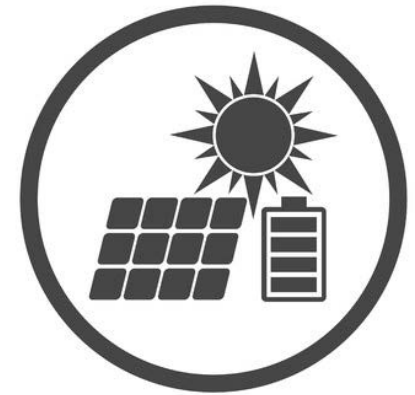

2

The Need for Energy Storage

The need for energy storage due to solar PV power profile

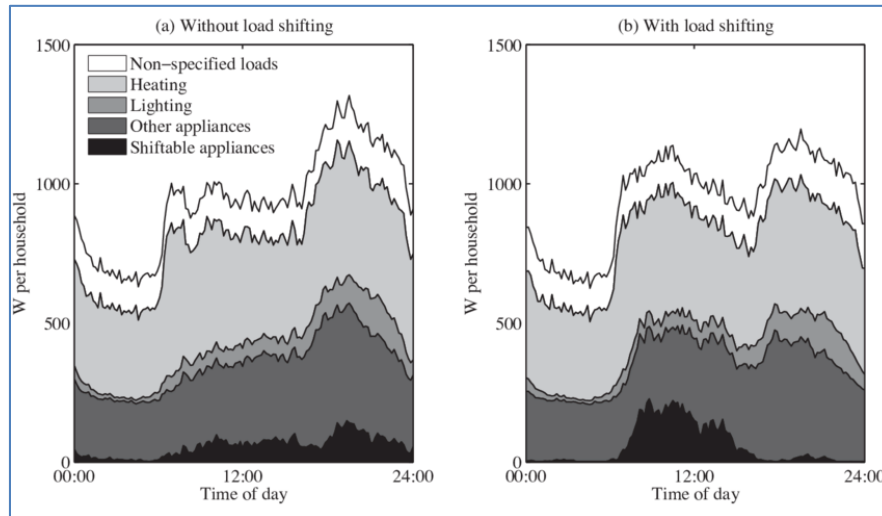

Joakim, W. & Joakim, M. (2019)

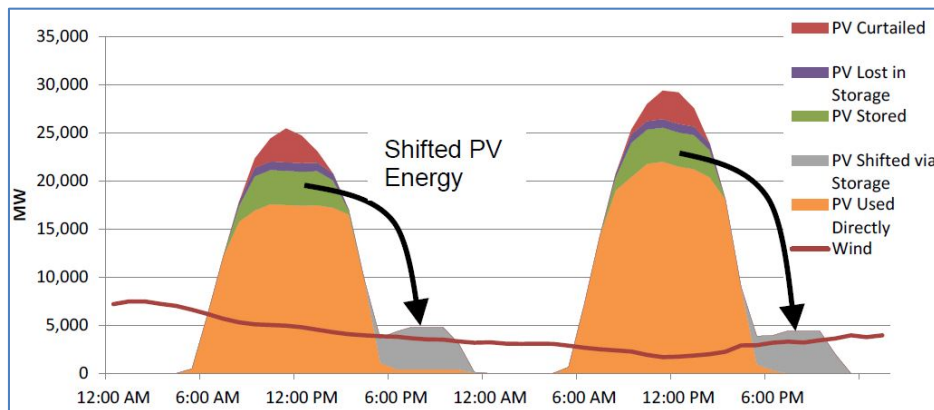

NREL (2016, pp 9)

- The solar PV generation profile peaks midday and has low efficiency in the early mornings and late afternoons
- Household load profiles peak in the mornings and late evenings, and plateau during the course of the day (assuming no load shifting)
- The need for energy storage for successfully integrating solar PV into the grid system is apparent

Storage technologies can help to integrate more intermittent renewable energy such as solar PV on the grid

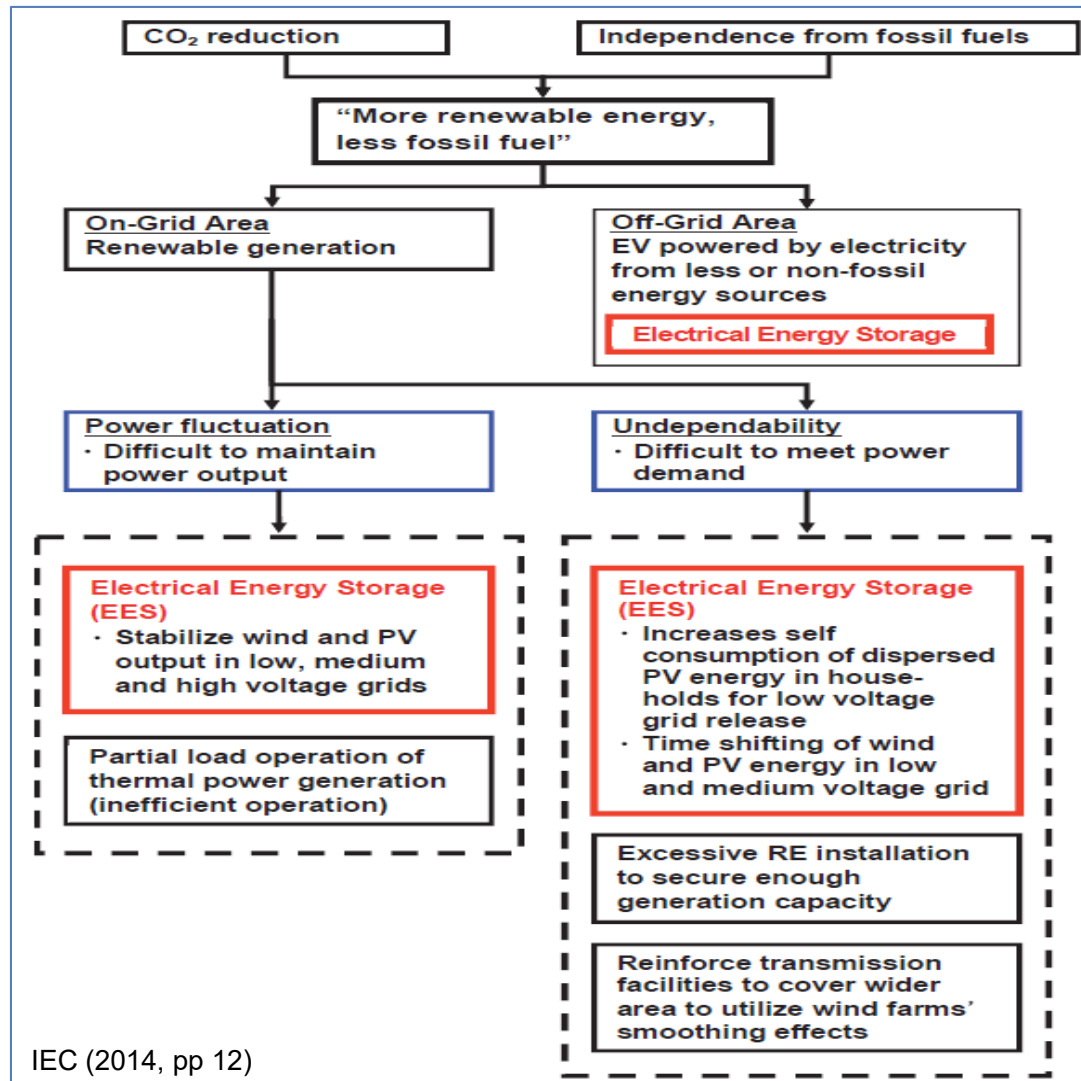

IEC (2014, pp 12)

- Storage helps to solve the undependability issue: intermittent power technologies such as solar PV without storage may require 'peaker' plants to meet peak demand, these are costly to operate. These costs are avoided with solar PV combined with storage
- Solar PV combined with storage enables the development of mini-grids in remote locations, where extending the grid to rural areas may be uneconomical and unfeasible due to high transmission costs and higher network failure risks.

Energy storage can deliver a vast number of services to support the integration of solar PV into the grid power supply



Bulk energy services	Ancillary services	Transmission infrastructure services	Distribution infrastructure services	Customer energy management services	Off-grid	Transport sector
Electric energy time shift (arbitrage)	Regulation	Transmission upgrade deferral	Distribution upgrade deferral	Power quality	Solar home systems	Electric 2/3 wheelers, buses, cars and commercial vehicles
Electric supply capacity	Spinning, non-spinning and supplemental reserves	Transmission congestion relief	Voltage support	Power reliability	Mini-grids: System stability services	
	Voltage support			Retail electric energy time shift	Mini-grids: Facilitating high share of VRE	
	Black start			Demand charge management		
				Increased self-consumption of solar PV		

Boxes in red: Energy storage services directly supporting the integration of variable renewable energy

IRENA (2017, pp 5)

The type of storage technology is dependent on the power, energy and/or storage duration required, and the service it delivers

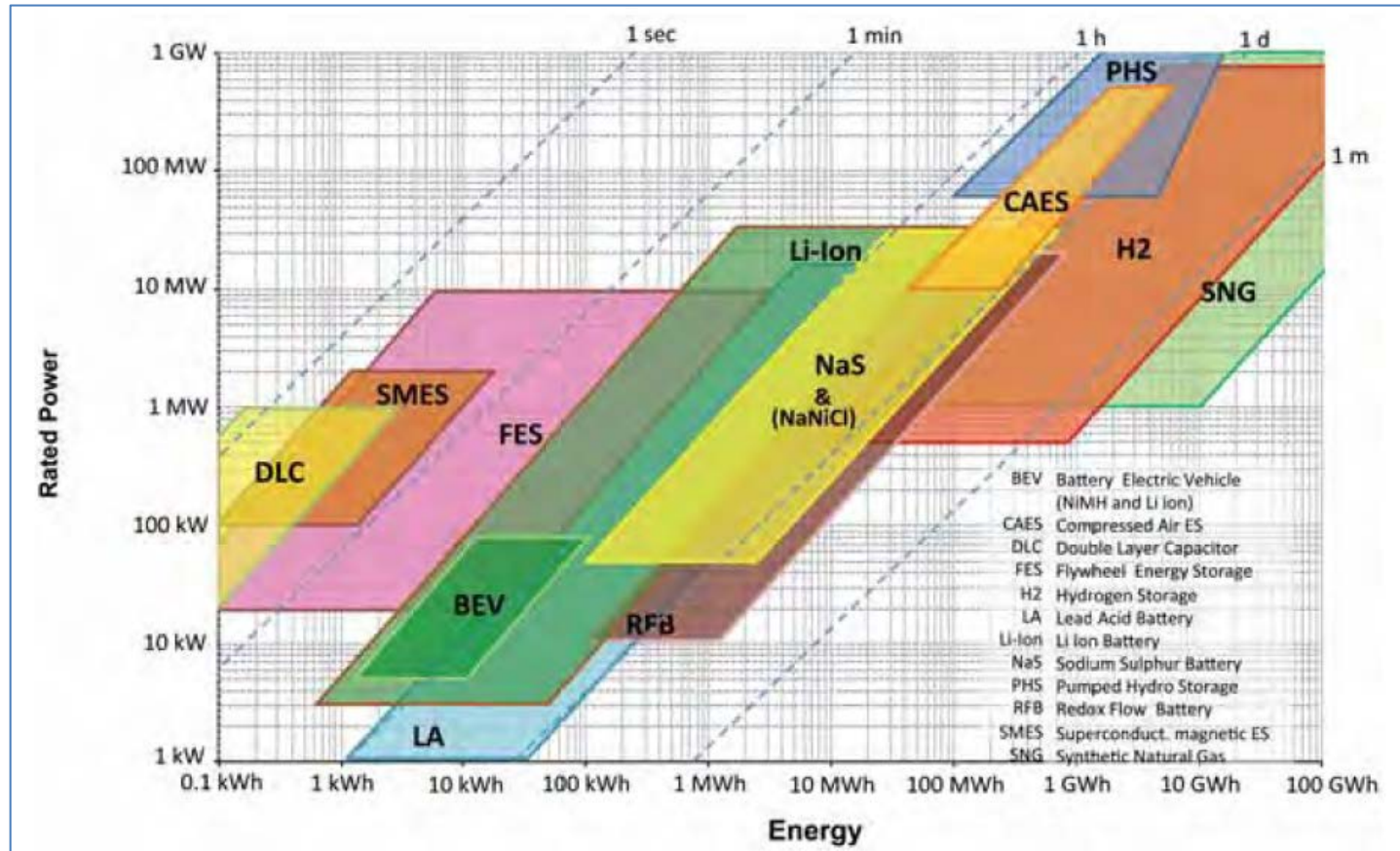

IEC (2014)

3

Solar PV combined with Storage Technology

Solar PV with battery storage is well-established, scalable, affordable and efficient for a variety of applications



- Battery technology is mature and proven using a variety of materials, although there is much room for innovation still.
- Batteries offer developers scalability (from pico-solar to utility-scale), high round-trip efficiency (80-95%) and are smaller (easier to transport/install) than the other technologies mentioned below.
- But other storage technologies might be suitable as well in the future, mainly for grid scale projects:
 - Pumped hydro storage requires significant upfront expenditure and is often used for bulk power management, and not at scales associated with solar PV projects.
 - Compressed air storage is a mature technology but is again not typically paired with individual solar PV projects and often requires suitable geology and a fossil-fuel source (natural gas) to heat the expanding air used to generate electricity.
 - Hydrogen storage from renewable energy sources is still in its infancy and is again not likely to be applied to individual solar PV projects but as a fossil-fuel substitute in industry and transportation.

The choice of battery technology will depend on the economics, specifications and energy usage.



Nikolaidis, P. Poullikkas, A. (2017)

Technology	Self-Discharge (%/day)	Life (years)	Cycles	Max. Depth of Discharge	Power Density (kWm ³)	Energy Density (kWhm ³)	Round Trip Efficiency (1)	Typical Discharge Time	Response Time	Cost Power (2)/(\$/kW)	Cost Energy (2) (\$/kwh)
Lead-Acid Battery	0.1-0.3	3-15	500-1,800	50%	90-700	50-80	70-90%	sec-hours	ms	300-600	50-400
Advanced Lead Acid Battery	0.1-0.3	5-15	2,200-4,500	100%	90-700	50-80	75-90%	min-hours	ms	300-600	425-1,150
Nickel-Cadmium Battery	0.2-0.6	15-20	800-3,500	80%	80-600	60-150	60-80%	sec-hours	ms	500-1,500	800-1,500
Lithium Ion Battery	0.1-5	10-20	300-20,000	80%	1,500-10,000	250-620	92 -97%	sec-hours	ms	175-4,000	200-3,800
Sodium Sulfur Battery	20%	12-20	2,500-4,500	90%	140-180	150-300	75-90%	sec-hours	ms	1,000-3,000	300-500
Sodium Nickel Chloride	15%	12-20	>2,500	80%	220-300	150-200	85-90%	sec-hours	ms	150-300	100-200
Vanadium Redox Flow	small	10-20	>2x10 ⁴	100%	<2	16-35	60-85%	sec-10hours	ms	500-1,500	150-1,000
Iron-Chromium Flow	small	10-20	1-1.5x10 ⁴	100%	<25	30-65	70-80%	sec-10hours	ms	1,200-1,900	300-400
Zinc-Bromine Flow	small	10-20	1-1.5x10 ⁴	100%	<25	30-65	65-80%	sec-10hours	ms	600-2,500	150-1,000

US Trade and Development Agency (2017)

- Lead-Acid batteries are typically cheaper than lithium-ion batteries but have a shorter lifespan which carries additional end-of-life considerations.
- VRFB have a low energy and power density and are therefore not suited to mobile applications, but well-suited to larger scale storage applications where economies of scale increase the competitiveness of their price relative to other battery types.

4

Solar PV combined with Storage examples

Home-scale solar combined with storage is used to provide affordable basic lighting and charging for rural households.



Nygaard, Hansen, & Larsen (2016)

- Solar PV panels ranging from 1-50W typically.
- Allows for LED lighting, USB charging, and radio/TV depending on the system size
- There are notable health and environmental benefits from this technology as it displaces kerosene lighting
- Batteries are built into the devices (lantern or cell phone) and used as needed or a stand-alone battery for the large solar home systems (SHS). Lead-acid batteries are typically used in SHS.

Solar PV combined with storage is used for off-grid telecommunications tower energy supply and mini-grid provision

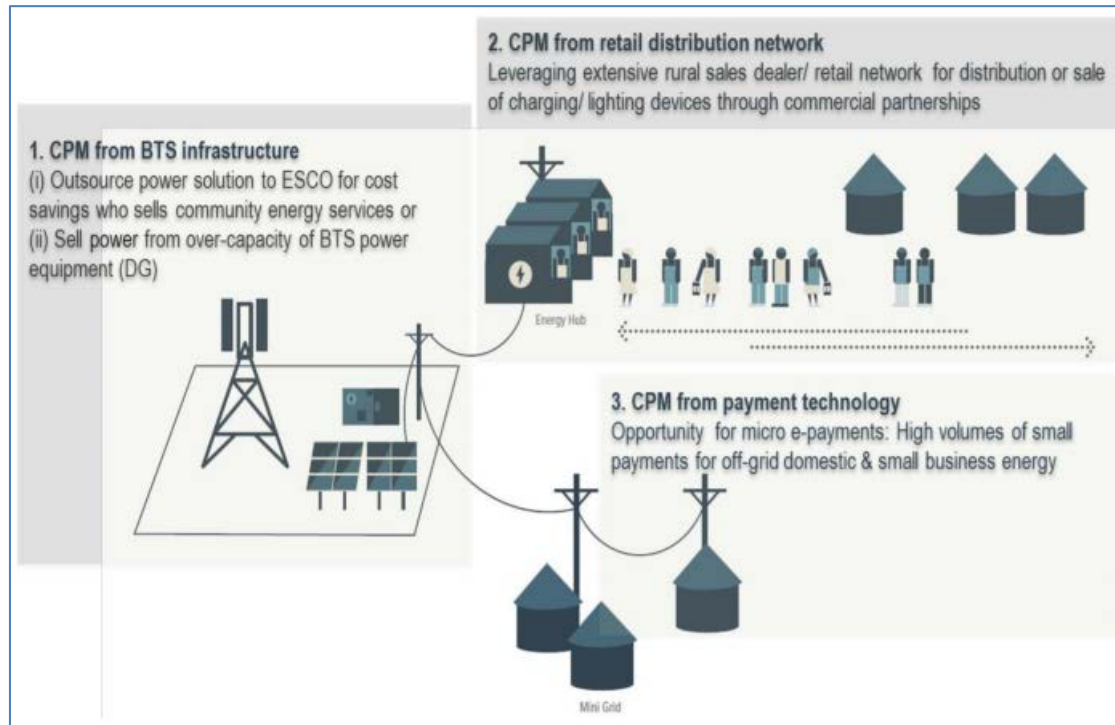

IFC (2016)

- Community Power from Mobile (CPM) model uses solar-plus-storage for electrification of remote telecommunications towers and base stations.
- Surplus energy from Base Transceiver Station (BTS) can be sold to nearby households and businesses to enable rural household electrification and productive energy uses.
- For example, refrigeration facilities for off-grid fishing communities in Kenya which reduces post-harvest seafood losses which can be up to a third of the seafood caught without refrigeration.

Solar PV combined with storage is used at utility-scale for renewable energy supply with network stabilisation



AfDB (2019)

- A 32MW solar-plus-storage project is being developed near N'Djamena in Chad under a private-public partnership as a first phase of a 60MW project.
- The project will have a 4 MWh battery system that is used for network stabilisation.
- This project assists with the Chadian Government's effort to address the power deficit in the country where only 10% of the population have access to electricity (Bellini, 2019)
- In developed countries, there are multiple examples of large solar PV projects combined with battery storage; however these types of projects are less common in developing environments. Although, it is expected to increase going forward.

5

Solar PV End-of-Life Management

Solar PV panels are composed of elements with high recyclability

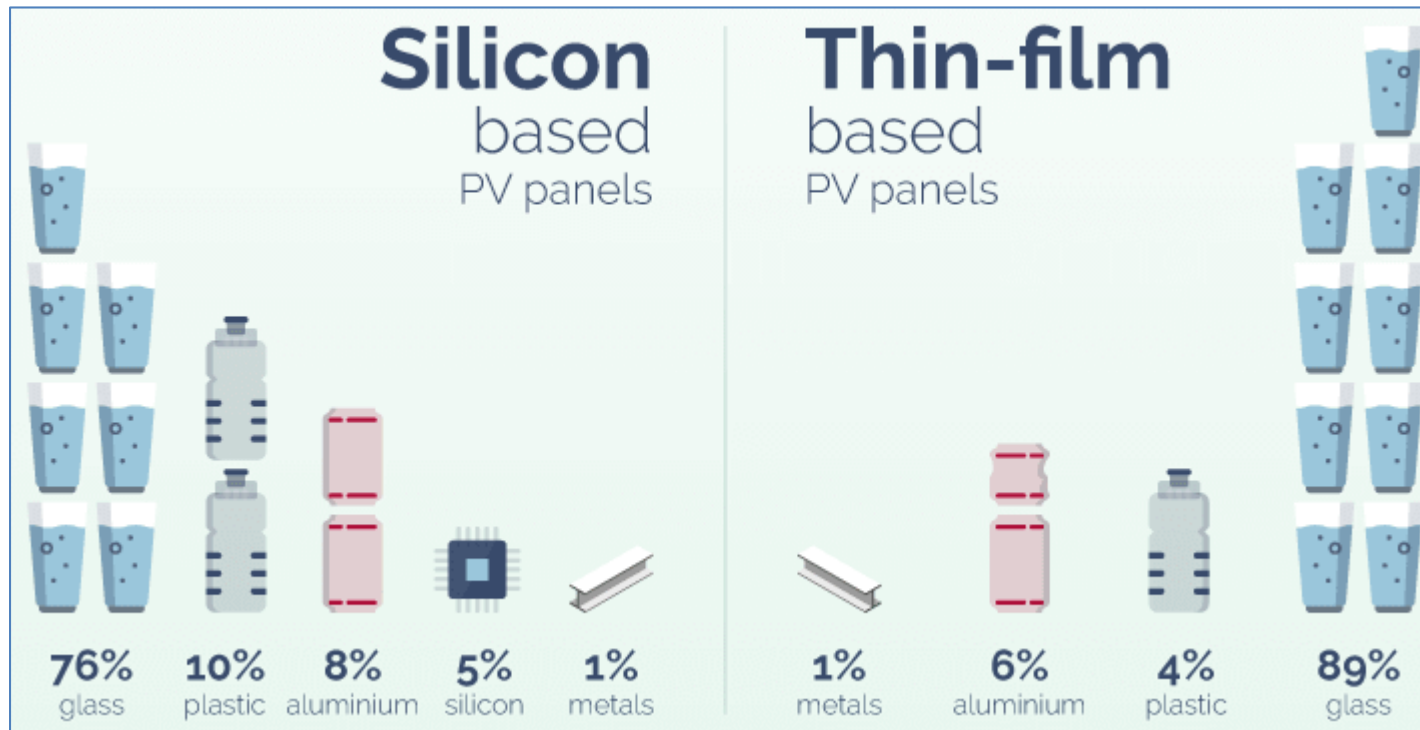

Sykorova, Lascar, & Vekony (2017)

- There are additional materials for end-of-life consideration from a solar PV project, such as the cabling and inverter components which contain metals such as copper and steel among other things
- The majority of solar PV projects use silicon-based panels with thin-film panels comprising around 10% of the capacity currently.

Solar PV waste projected to increase substantially in future

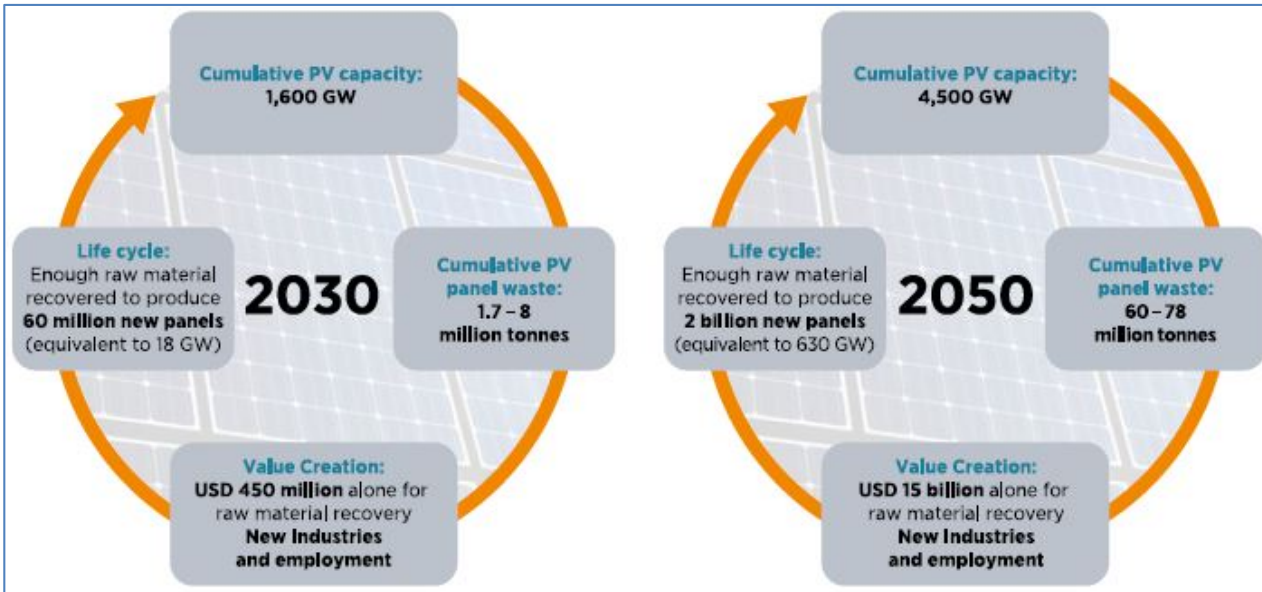

IRENA & IEA-PVPS (2016, pp 13)

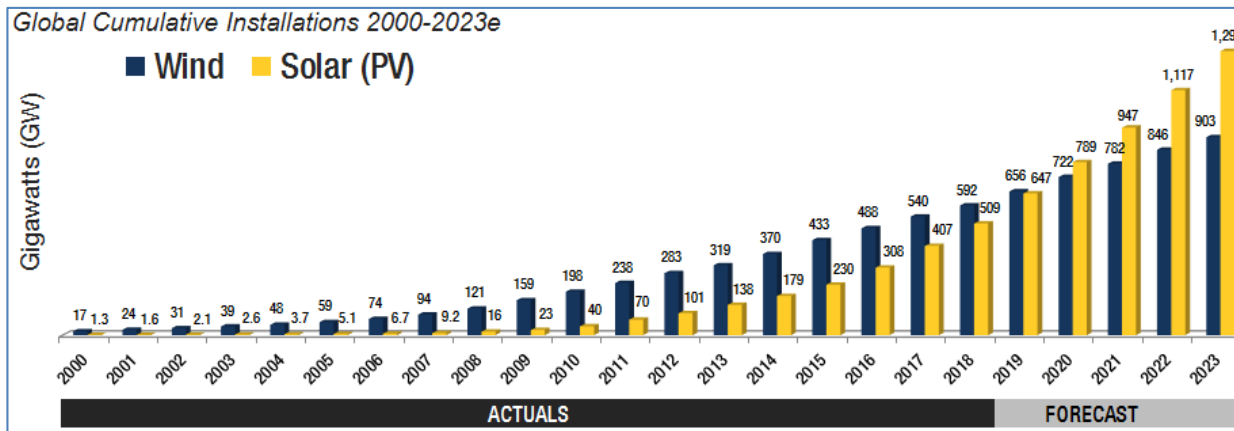

FI-Powerweb (2019)

- By the end of 2016, there was an estimated solar PV waste of between 43,000 and 250,000 tonnes
- PV panel waste is a function of PV capacity which has been increasing rapidly in recent years
- As solar PV panel mass-to-power ratio drops, so too does the waste per unit power capacity.

The cradle-to-gate of solar PV panels represents three broad options for waste management

- As solar PV panel mass-to-power ratio drops, the demand for material in the panel manufacture is reduced
- Defective panels and panels at/or nearing the end of their lifespan (30-years) can be returned and repaired/refurbished for reuse. These panels are often sold as replacements or as used panels (at typically 70% of the original cost)
- Recycling requires specialised facilities which favours utility-scale PV projects for economical efficiencies associated with dismantling, collection, and transportation.

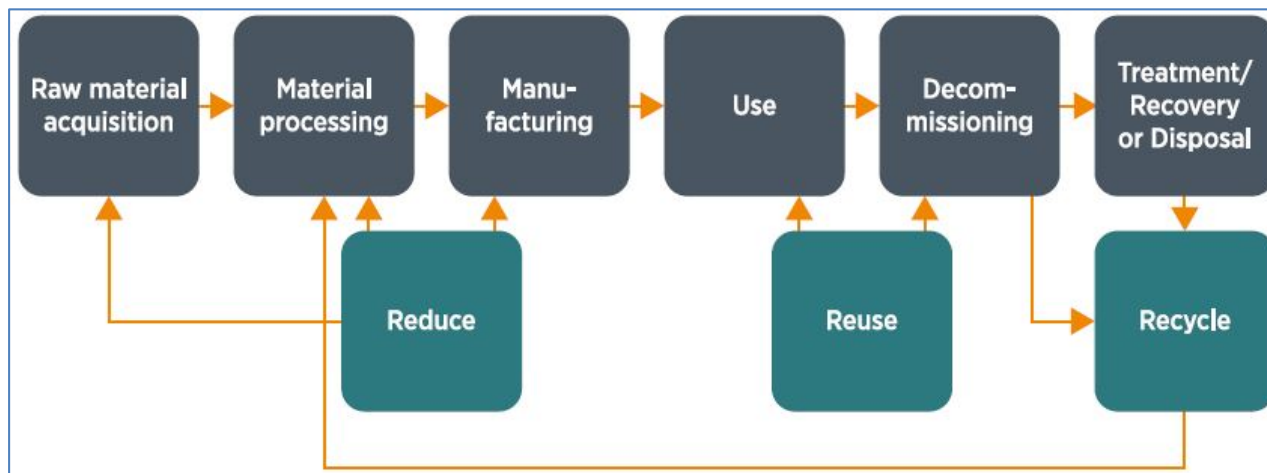

IRENA & IEA-PVPS (2016, pp 47)

Recycling si-solar PV components through mechanical, chemical and thermal processes

Silicon panel versus Thin-Film Panel Recycling



Sykorova, Lascar, & Vekony (2017)

- By mass, a crystalline silicon solar PV panel is over 75% glass, 10% ethylene-vinyl acetate (EVA) for the back sheet, 8% aluminium frame, 6% silicon cells, and traces of other metals.
- By value, the priorities are different:

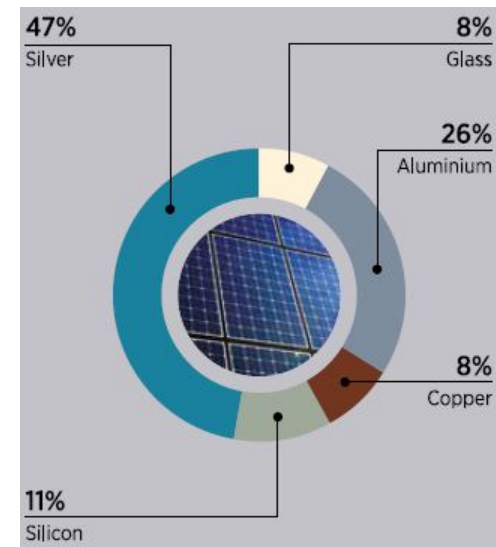

IRENA & IEA-PVPS (2016, pp 78)

Waste Electrical and Electronic Equipment (WEEE) Directive is the only legislation that regulates solar PV disposal and recycling



- The EU is the only region with dedicated solar PV component disposal and recycling legislation.
- Encouraging recycling through policies and subsidies could reduce the amount sent to landfill but would also reduce reuse/repurposing and repair.
- Currently, solar PV component recycling is not feasible without charging fees to either the consumer or the provider.
- If the consumer is charged for recycling, this decreases the return rates (financial incentive to landfill the components)
- If the provider is responsible for the recycling costs, it increases the cost of solar PV components and reduces profits which may limit cost reductions and thus solar PV uptake.
- The geography of many solar PV projects poses a threat to the recycling as collecting and transporting the components places increasing financial burden on either the consumer or the provider.
- A solar panel recycling plant has been established in France as the volumes of panels reaching end-of-life justified having a designated facility.

Overview of legislation on solar PV end-of-life treatment in other geographies



Country	Legislation Status
Japan	Still in the process of developing recycling legislation. 2017 issued voluntary guidelines on proper solar PV disposal following on from the 2015 solar PV end-of-life roadmap. No official regulations for solar PV end-of-life management to date.
USA	No specific laws for collecting, handling and use of end-of-life solar PV modules. California and Washington states have implemented bills that regulate solar PV modules and end-of-life treatment. US Solar Power Industries Association (SEIA) is developing a waste management strategy and circular economy objectives for the industry.
China	Solar PV panels are not included in the waste electrical and electronic products processing directory of the regulations. The 13 th 5-Year Plan for 2016-2020 proposed directions for accelerating end-of-life management of waste PV modules but no official regulations applied currently.
Korea	No specific guidelines or regulations governing end-of-life management of solar PV waste. There are two projects for PV module recycling (2 tonnes per day), funded in 2016 that are being used to research, develop and demonstrate recycling facilities
India	India has no regulations on PV component collection, recovery and recycling of end-of-life modules. Solar PV waste is currently treated under general waste regulations.

Sharma *et al.* (2019)

6

Batteries End-of-Life Management

Batteries have a variety of constituents and materials with varying toxicities

Typical Secondary Battery Operation

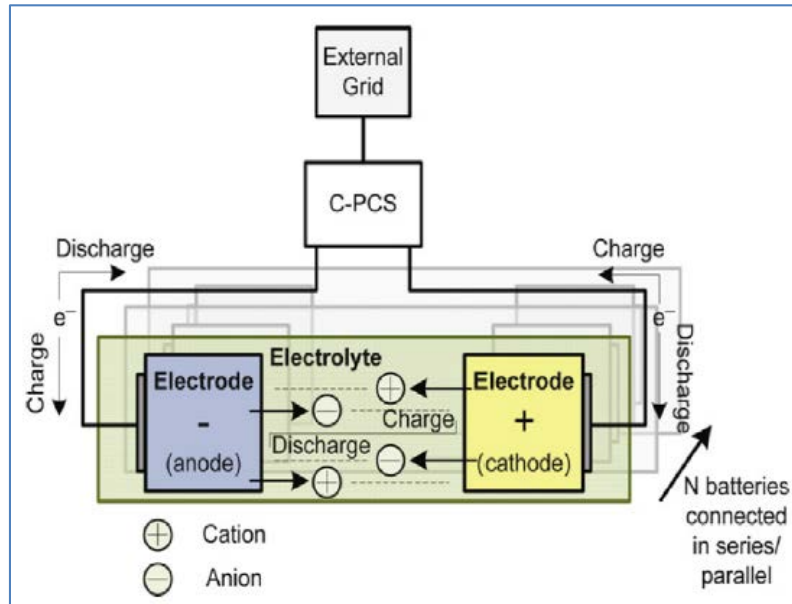

Altin, N. (2016)

Typical Flow Battery Operation

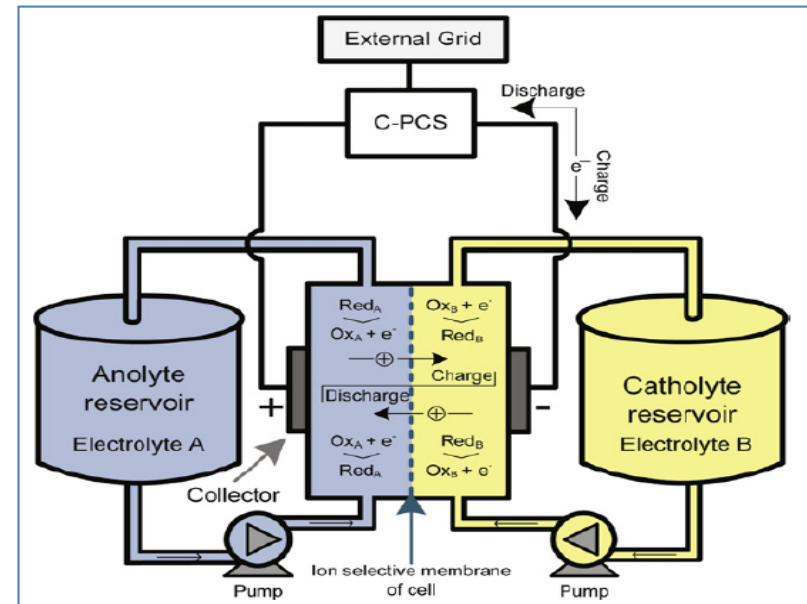

Altin, N. (2016)

- Wide variety of elements used in secondary battery storage technologies, from lead, sodium, calcium, and more recently lithium-ion.
- Flow batteries are relatively new battery technologies. Typical flow batteries on the commercial market include vanadium redox, polysulphide bromide, and zinc bromine batteries.

Battery energy storage recycling impacts vary by technology type

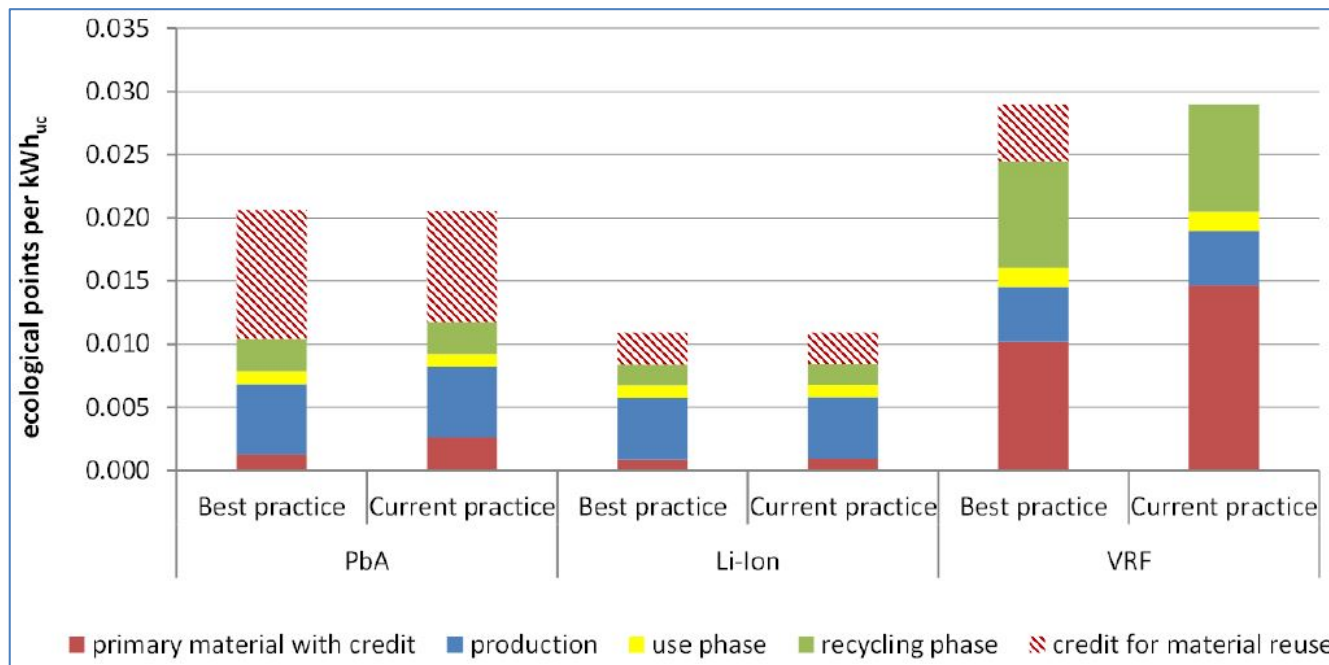

Unterreiner *et al.* (2016, pp 231)

- Based on a life-cycle assessment study, currently 57% of lead-acid materials are recycled and reused in manufacture. The lead is infinitely recyclable and most of the other materials are recyclable
- Currently 49% of LIBs are being recycled and reused in manufacture. Lithium material reuse is currently limited by the economics of recycling.
- VRFB is not widely used and there is currently sparse recycling capacity available; however, the battery containers have a high plastic content which is expected to reduce their recyclability. That said, the toxicity of the electrolyte is low and can be easily reused, which makes this technology promising in terms of reusability.

Lead-Acid batteries are highly recyclable but the materials highly toxic

Informal lead-acid battery recycling



Ballantyne *et al.* (2018)

- Lead is a highly toxic substance with notable human health and environmental impacts if not managed properly.
- 95-98% of lead-acid batteries are currently recycled and the recycling industry for this technology are well developed and profitable.
- With recent proliferation of pay-as-you-go solar, there will be significant end-of-life implications for developers regarding the batteries.
- Informal recyclers can recycle the batteries cheaper and offer a higher price to users than formal recyclers. For example, the Bangladesh solar home system (SHS) programme initially experience an issue with the batteries being informally dismantled and recycled – to the detriment of the environment and the health of the informal recyclers
- In Bangladesh case, the programme had to offer \$5 incentive to formal recyclers and \$5 to collectors to reduce the amount of batteries being sent to hazardous recycling facilities

Lithium battery recycling in early stages but with notable potential

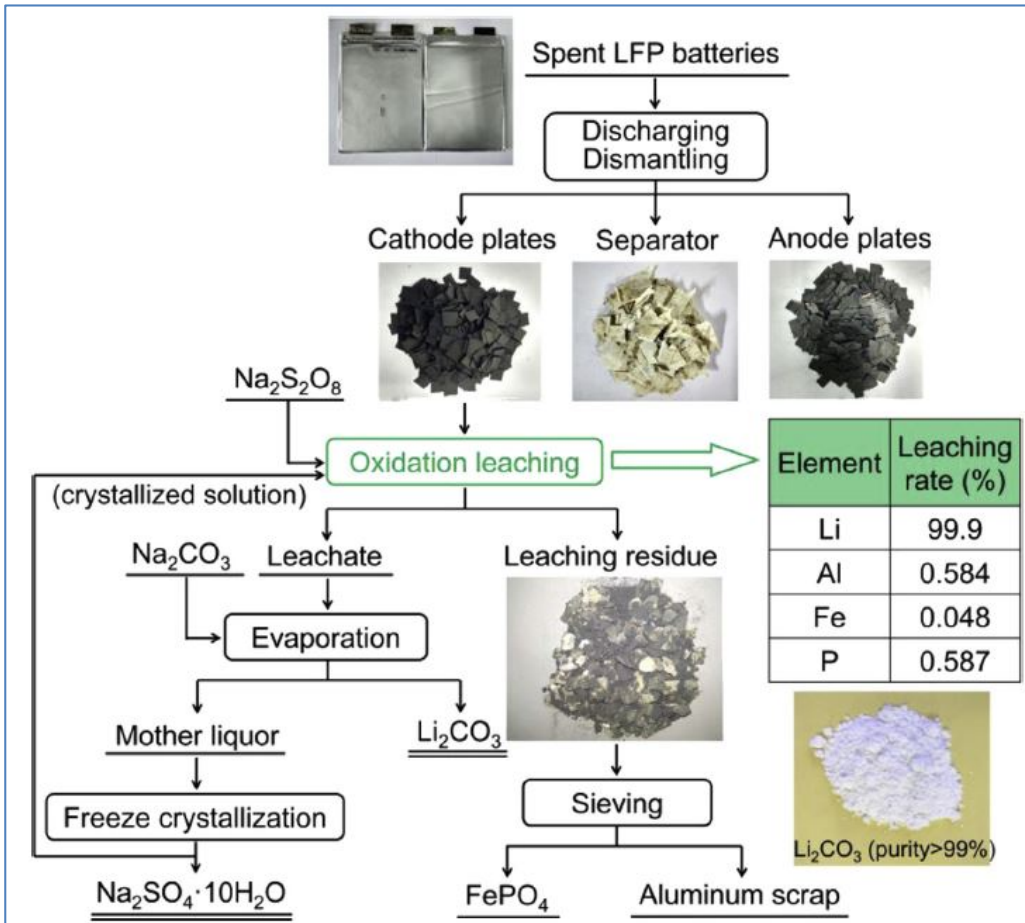

Pagliari & Meneguzzo (2019, pp 5)

- 7 materials comprise >90% of the economic value of spent LIBs: cobalt, lithium, copper, graphite, nickel, aluminium, and manganese
- Recycling facilities are being established around the globe by battery manufacturers
- Regulation of battery recycling is still in infancy but it is progressing
- Recycled lithium will reach 9% of total lithium supply by 2025
- Innovative recycling technologies using citric acid and phosphoric acid are promising techniques to leach lithium from spent batteries affordably and with little toxicity.
- However, for lithium-ion batteries the value of materials recovered from recycling does not compensate for collection, separation and extraction of said materials and there is therefore still an out-of-pocket recycling payment needed, unlike lead-acid batteries.

Solar PV combined with Lithium-ion battery (LIB) can be a way to extend usable life of Electric Vehicles batteries

- Stationary applications need less current density from batteries. Electric vehicle (EV) batteries with 80-85% of their original capacity are collected for reuse in stationary applications
- Second-life LIBs are becoming increasingly popular for reuse in grid, building and telecommunication tower applications and are reportedly priced at less than \$100/KWh.
- By 2025, 75% of used EV batteries will be reused for stationary applications such as this solar PV application.
- The Joahn Cruyff Arena in Amsterdam installed an energy storage system in 2018 with 3 MW/2.8 MWh capacity using 250 repurposed lithium-ion batteries (LIBs) and 340 new LIBs which is used to store energy from the solar panels on the stadium roof
- This energy storage system provides the stadium with frequency control, and load shaving.



Pagliari & Meneguzzo (2019, pp 2)

VRFB end-of-life management still in infancy but the materials are highly recyclable

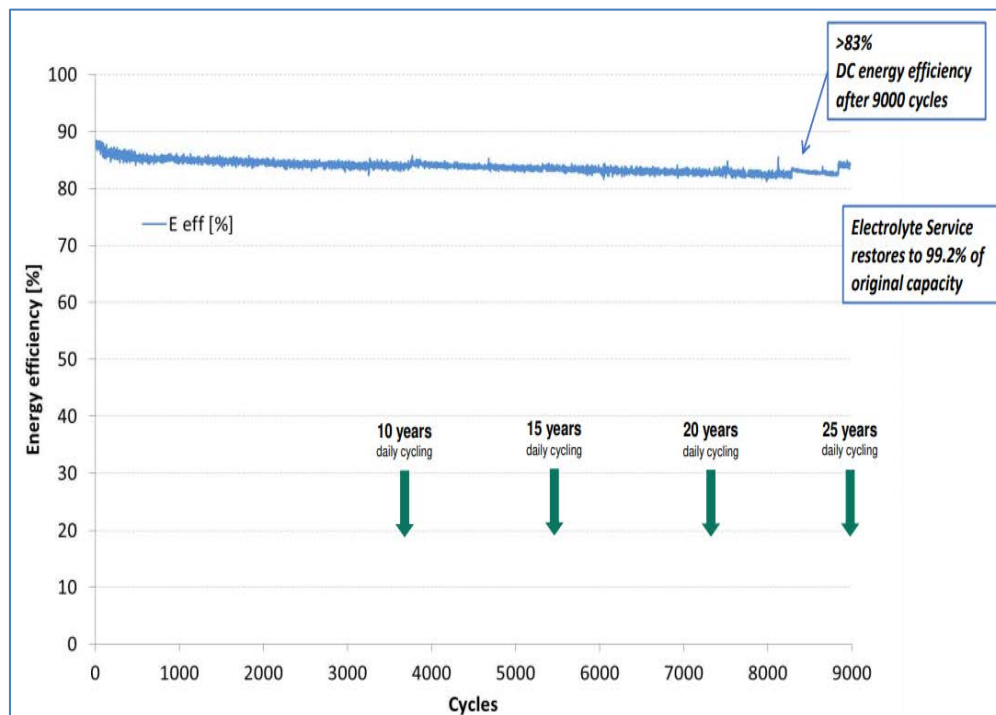

VSUN Energy (2017)

- VRFB have a longer lifespan than LIBs or lead-acid batteries which reduces their end-of-life burden as they are replaced less frequently
- The electrolyte used in VRFB has a low toxicity, is non-flammable and easily upgraded for reuse.
- A company has been able to use vanadium in fly ash, oil field sludge and mining slag to reduce the need for mined vanadium and use these waste streams.
- Using recycled vanadium reduces the cost of the battery materials and reduces the environmental footprint of this technology

7

Conclusion

Final remarks



- The choice of battery technology used to combine with solar PV depends on the costs, and specifications of the battery.
- Solar PV combined with storage can deliver a vast range of applications from household electrification, telecommunications tower power supply, to utility-scale projects with network stabilisation services.
- Solar PV components are currently being reused, refurbished and recycled; however, only the EU has solar PV specific legislation and regulations on disposal and recycling; however, progress is being made in the USA and Japan on regulating this waste.
- Due to the recent proliferation in solar PV capacity, the amount of PV waste that needs to be responsibly managed is rapidly increasing too, as these components reach the end-of-life phase.
- In order to achieve true sustainability, the end-of-life treatment of both the solar PV components and the storage components need to be managed in such a way that environmental impacts are mitigated, material reuse is maximised and recycling processes are made economical.
- Lead-acid battery recycling is mature and prolific; however, informal recycling facilities may have insufficient health and environmental procedures in place.
- Lithium-ion battery recycling is in its infancy but is expanding. Currently, recycling it is not feasible without out-of-pocket fees being paid to recyclers.

References



- AfDB (2019), *Summary of the environmental and social impact assessment (ESIA)*, African Development Bank, URL: <https://www.afdb.org/en/documents/chad-djermaya-solar-power-plant-project-32-mwc-summary-esia>, Access Date: 12/11/2019.
- Altin, N. (2016), *Energy Storage Systems and Power System Stability*, 3rd International Smart Grid Workshop and Certificate Programme, Istanbul, Turkey.
- Ballantyne, AD., Hallett, JP., Riley, DJ., Shah, N., & Payne, DJ. (2018), *Lead acid battery recycling in the twenty-first century*, Royal Society Open Science, URL: <https://royalsocietypublishing.org/doi/10.1098/rsos.171368>.
- Bellini, E. (October 4, 2019), *Chad gets financing for large scale solar-plus-storage project*, PV Magazine, URL: <https://www.pv-magazine.com/2019/10/04/chad-gets-financing-for-large-scale-solar-plus-storage-project/>, Access Date: 12/11/2019.
- EIA (2019), *Solar PV output depends on orientation, tilt, and tracking*, URL: <https://www.eia.gov/todayinenergy/detail.php?id=18871#>, Access Date: 18/10/2019.
- FI-Powerweb (2019), *Renewable Energy*, Forecast International's Energy Portal Website, URL: <http://www.fi-powerweb.com/Renewable-Energy.html>, Access Date: 12/11/2019.
- IEC (2014), *Electrical Energy Storage*, URL: <https://www.iec.ch/whitepaper/pdf/iecWP-energystorage-LR-en.pdf>, Access Date: 18/10/2019.
- IFC (2016), *Energy Storage: Business Solutions for Emerging Markets*, EMCompass, IFC a member of the World Bank Group.
- IRENA (2017), *Electricity Storage and Renewables: Costs and Markets to 2030*, International Renewable Energy Agency, Abu Dhabi.
- IRENA & IEA-PVPS (2016), *End-of-life management: Solar photovoltaic panels*, International Renewable Energy Agency and International Energy Agency Photovoltaic Power Systems.
- Joakim, W. & Joakim, W. (2013), *Evaluating the benefits of a solar home energy management system: impacts on photovoltaic power production value and grid interaction*, ResearchGate.
- NREL (2016), *Energy storage requirements for achieving 50% solar photovoltaic energy penetration in California*, National Renewable Energy Laboratory.
- Nygaard, I., Hansen, U.E., & Larsen, T.H. (2016), *The emerging market for pico-scale solar PV systems in Sub-Saharan Africa: From donor-supported niches towards market-based rural electrification*, UNEP DTU Partnership.
- Pagliaro, M. & Meneguzzo, F. (2019), *Lithium battery reusing and recycling: A circular economy insight*, Heliyon, DOI: 10.1016
- Ruiz, I. (2016), *Hydrogen and wind: Allies for sustainable energy*, DW, URL: <https://p.dw.com/p/1J6iM>, Access Date: 18/10/2019.
- Sharma, A., Pandey, S., & Kolhe, M. (2019), *Global review of policies & guidelines for recycling of solar PV modules*, International Journal of Smart Grid and Clean Energy, 597-610.
- Sykorova, B., Lascar, A., & Vekony, A.T. (2017), *A Solar Panels Life after Death*, Greenmatch, URL: <https://www.greenmatch.co.uk/blog/2017/10/the-opportunities-of-solar-panel-recycling>, Access Date: 12/11/2019.
- Unterreiner, L., Jülch, V., Reith, S. (2016), *Recycling battery technologies- Ecological impact analysis using life cycle assessment (LCA)*, Energy Procedia.
- US Trade and Development Agency (2017), *South Africa Energy Storage Technology and Market Assessment*, Parsons Job Number: 640368.
- VSUN Energy (2017), *Understanding battery life – vanadium redox flow batteries*, Australian Solar Council 2017 Solar Exhibition & Conference

Supporters of this Expert Training Series

